

May 30

15 Cents

RADIO WORLD

Title Reg. U.S. Pat. Off.

Vol. 7. No. 10. ILLUSTRATED Every Week

1-Control Neutrodyne
Adding RF, but Not An
Extra Control

**1-Tube Ballantine
Reflex Set**

Radio-Frequency, Detector and Audio-Frequency, All on One Tube!

1-TUBE SET WORKS SPEAKER!

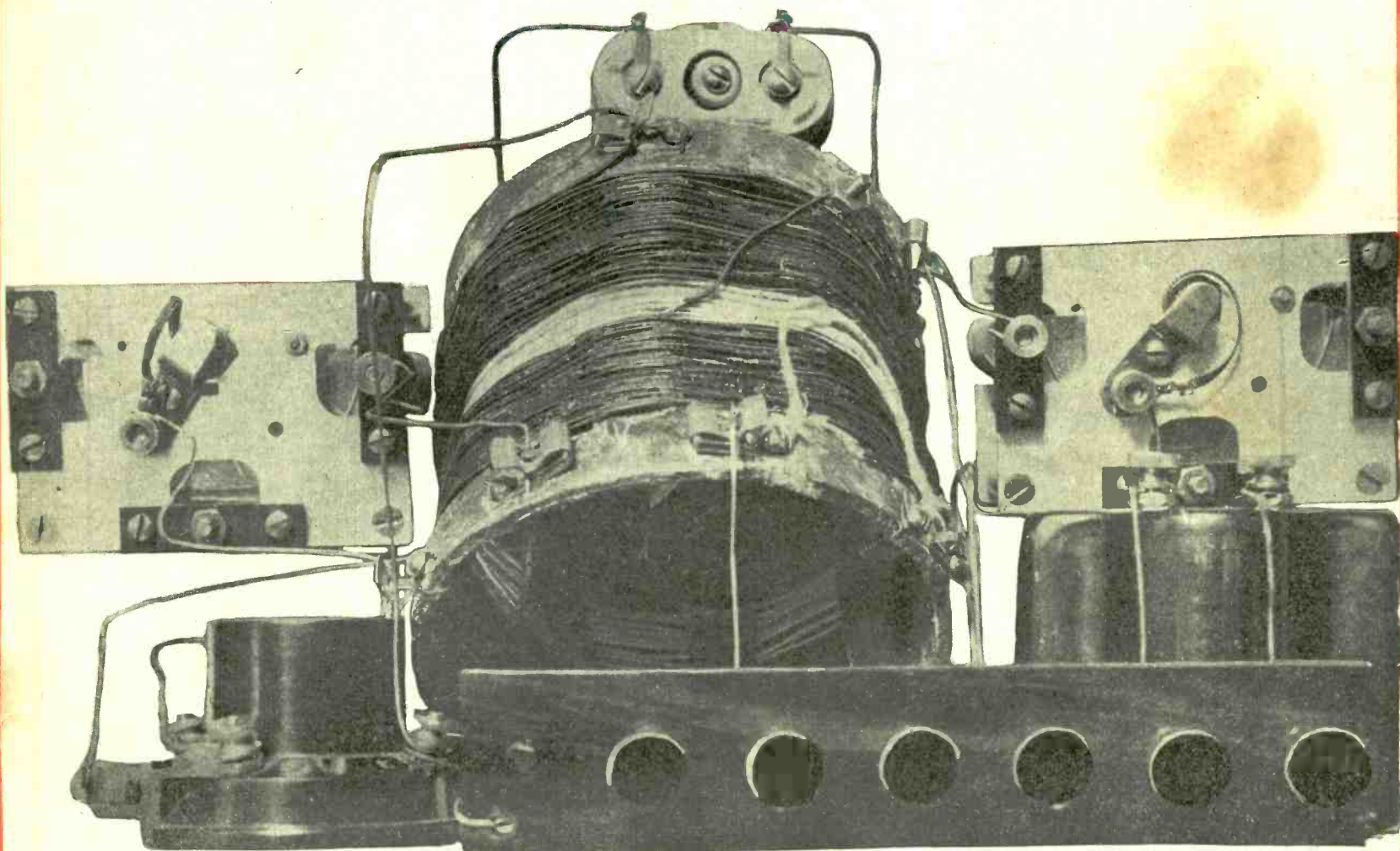

LOCALS COME IN ON A HORN!

Ultra-Audion Circuit Modified and Improved Reflex Results

How to Make Your Set Tune in
the Whole Band of Wavelengths

By J. E. Anderson

The Diamond of the Air as a 2-
Control DX Receiver

By Herman Bernard



Solid Rubber Case

You Save 50%

World 6-Volt Storage Batteries are famous for their guaranteed quality and service. Backed by years of Successful Manufacture and Thousands of Satisfied Users. You save 50% and get a

2-Year Guarantee Bond In Writing

World Battery owners "tell their friends." That's our best proof of performance. Send your order in today.

RADIO BATTERIES	
6-Volt, 100-Amperes	\$12.25
6-Volt, 120-Amperes	14.25
6-Volt, 140-Amperes	16.00
AUTO BATTERIES	
6-Volt, 11-Plate	\$12.25
6-Volt, 13-Plate	14.25
12-Volt, 7-Plate	17.00

SEND NO MONEY
Just state battery wanted and we will ship day order is received, by Express C. O. D., subject to your examination on arrival.

Extra Offer: 5% discount for cash in full with order. Buy now and get a guaranteed battery at 50% saving to you.

WORLD BATTERY COMPANY
1219 S. Wabash Ave., Dept. 17 Chicago, Ill.



Approved and Listed as Standard by Leading Authorities

including Radio News Laboratories, Popular Science Institute of Standards, Popular Radio Laboratories, Radio Broadcast Laboratories and Lefax, Inc.

Solid Rubber Container

Now Standard equipment on all World Storage Batteries. No more leakage or breakage of jars or rotting of box.

THE DAVEN SUPER AMPLIFIER

To obtain perfect tone from your receiver, it is essential that it be Resistance Coupled. The Super Amplifier is a completely assembled Resistance Coupled Unit. With it you get more volume of perfect quality and economy in "B" Battery consumption.

Amplifier Kits in 3' or 4-stage. Easy to assemble—ideal for those who like to build. The "Resistor Manual" at your Dealer 25 cents, Postpaid 35 cents.

The Son of Abel
DAVEN RADIO CORPORATION
Resistor Specialists
NEWARK, N. J.

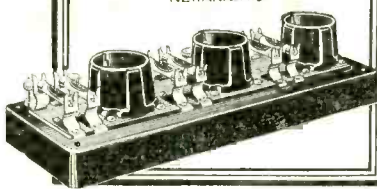

HAVE YOU ANYTHING TO SELL OR EXCHANGE? Use RADIO WORLD'S Classified Department and get great results. RADIO WORLD, 1493 Broadway, N. Y.

NOW \$3.50 COD

Direct from factory to you

THE RABAT SENIOR
4200 MIL. AMPS. CAPACITY

For a Limited Time Only

You can purchase for \$3.50 a 12 cell 24 volt RABAT SENIOR battery. Saving \$6.10 thru direct buying. 24 cell 48 volt size \$7.00

Rabat Senior batteries are neat, powerful, noiseless. Separate clear glass cells and patented rubber cork with heavy duty plates 3/16" x 1" x 2 1/2" with staggered ribbed grid form the backbone of this sturdy battery. Shipped completely charged ready to use. Order now, save \$6.10

Rabat Super Charger \$3.00 c. o. d.
Specially designed to satisfactorily recharge any storage "B" battery. Shipped complete ready to use, including lamp socket, attachment plug and cord. You save \$1.50 by ordering direct.

Send No Money but order today. After examining and approving these batteries pay Expressman the small c. o. d. charges. RABATS are guaranteed two years.

THE RADIO RABAT COMPANY
1766 ST. CLAIR AVE. CLEVELAND, OHIO

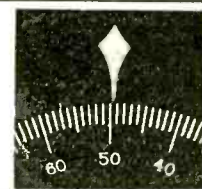

EUREKA DIAL POINTER

10c Each—Nickel Finish Dealers Display Card. \$3.25 Net

Obtain at your dealer's or sample mailed upon receipt of stamps.

C. W. BUTTS, INC.
42 Hedden Place East Orange, N. J.

Radio and Other Technical Books You Need

Radio Telegraph and Telephone Receivers for Beginners	\$.75
Design Data for Radio Transmitters and Receivers—M. B. Sleeper75
Wireless in the Home—De Forest15
Commercial Type Radio Apparatus—M. B. Sleeper75
A B C of Vacuum Tubes—Lewis	1.00
Operation of Wireless Telegraph Apparatus35
Lessons in Wireless Telegraphy35
Radio Hookups—M. B. Sleeper75
Construction of New Type Trans-Atlantic Receiving Sets—M. B. Sleeper75
1922 Consolidated Call Book50
How to Make a Standard C W Set35

Any book sent on receipt of price, postpaid. 20% discount on any two books of same title. The whole list of 11 books sent for

\$6.45

THE COLUMBIA PRINT
1493 Broadway, New York City

HOW TO BUILD A NEUTRALIZED LOOP, by Frank Freer. Send 15c for May 2 issue, RADIO WORLD.

THE DIAMOND OF THE AIR, by Herman Bernard, a 4-tube DX loop set of tremendous range and power. Three controls. Not refilled. Send 30 cents for the April 4 and 11 issues. RADIO WORLD, 1493 Broadway, New York City.

For Hayden's "Baby Portable"

use the



No. 99

Junior Coil. **\$5.50**

List Price

FREE—1 pkg. Bruno Engravings with each kit.

LIST OF PARTS FURNISHED

- 1—Bruno 99 Junior Coil
- 1—Lacault Condenser
- 1—Dubilier No. 640 Grid Condenser
- 1—Dubilier .0005 By-pass Condenser
- 1—No. 4 Saturn Jack
- 1—Bruno WD11 Socket
- 1—Drilled Panel
- 1—2 meg. Grid Leak
- 2—Kurz-Kasch Control Knobs
- 1—6 ohm Bruno Rheostat
- Bus Bar



Wound on Quartzite. Tunes from 175-575 meters with .0005 condenser.

Complete Kit

for Hayden's Portable

\$13.95

(including drilled panel)

Complete Kit for 2-Control "Diamond of the Air"

\$41.50

With Loop \$46.50

Complete Kit for 1925 Superdyne \$39.50

Write us for our

FREE

Catalogue

220 FULTON ST., NEW YORK



B.C.L. RADIO SERVICE CO.

Fourth Annual Vacation Number RADIO WORLD Out Next Week

Dated June 6

Last color form closes May 25. Last black form closes May 26.

Hundreds of thousands of radioists or potential radio fans will be going to the country within the coming few weeks. This issue is intended for their guidance in buying radio sets and parts.

RADIO WORLD dated June 6 will be our Fourth Annual Vacation Number, and will contain special summer features, service articles, illustrations and warm weather helps by experts.

The regular advertising rates in force: \$300 per page; \$150 half page; one-third page (1 column) \$100; one-quarter page \$75. \$10 inch, 75c per line. Times Discounts.

If you want to increase your summer sales among radio fans who actually buy radio goods during the summer, be sure to be represented in RADIO WORLD'S FOURTH ANNUAL VACATION NUMBER.

Wire, write or phone for space in this Business-Increasing Number.

Advertising Manager, F. S. CLARK, 1493 Broadway, New York City

Phones: Lackawanna 2063-6376

RADIO WORLD

[Entered as second-class matter, March, 1922, at the post office at New York, N. Y., under the Act of March 3, 1879]

A Weekly Paper Published by Hennessy Radio Publications Corporation from Publication Office, 1493 Broadway, New York, N. Y. Phones: Lackawanna 6976 and 2063

Vol. VII. No. 10. Whole No. 166.

May 30, 1925

15c per copy, \$6.00 a year

A Set That Uses the Detector Also for an AF Stage

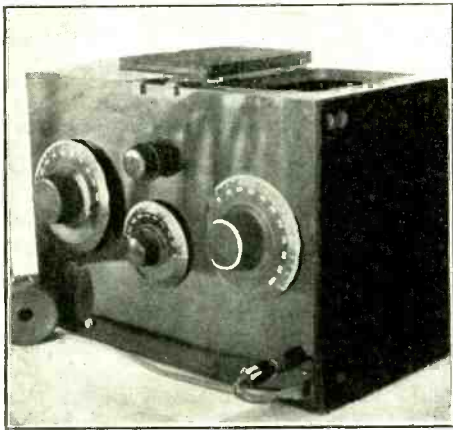

THE COMPLETED SET which is easily portable. A strap may be attached to anchorages at the sides of the cabinet.

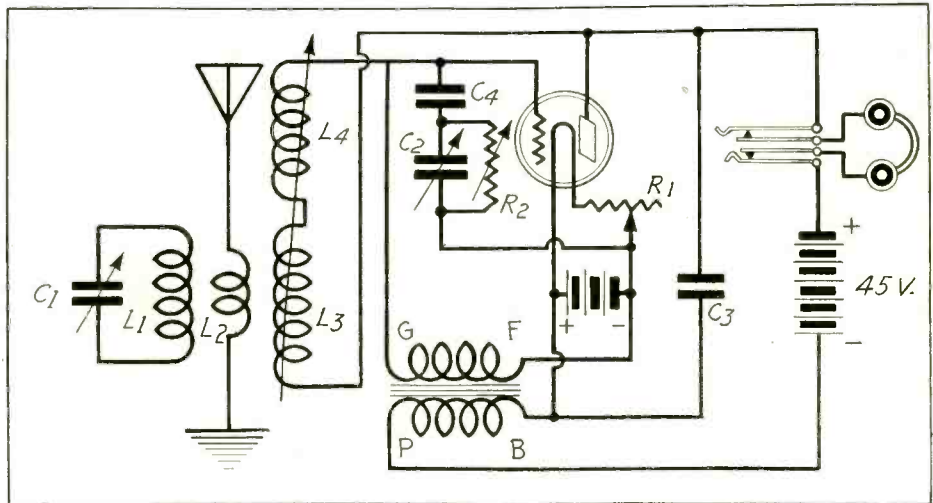

THE WIRING diagram of Lindheim's Reflex, a selective circuit.

By *Burton Lindheim*

Illustrations by *Walter James*

THE Ultra-Audion reflex employs a tube as the detector and is also reflexed for one stage of audio-frequency amplification, no crystal being used. With this set locals can be received on the speaker and DX stations will afford good volume on the ear phones. The set is very selective. A 7x14" cabinet is used. It is easily portable.

Having always preferred the Ultra-Audion to the usual regenerative hook-ups for smoother control of oscillation, I experimented and improved its selectivity by means of a special tuner, greatly increasing volume by reflexing.

Special Coupler Is Used

Fig. 1 shows the conventional 2-circuit Ultra-Audion tuner improved by the addition of a wavetrapp and a variometer effect, and with an audio-frequency transformer incorporated into the circuit. The constants of the circuit are: L1L2L3L4, the special coupler; C1 and C2, low-loss variable condensers, .0005 mfd. each; C3, fixed condenser, .002 mfd.; R1, a 6-ohm vernier rheostat; R2, a variable grid leak; and a high-ratio audio-frequency transformer.

The special coupler required for the set has three circuits. L1 roughly corresponds to a wavetrapp which materially increases the selectivity. L2 is the untuned or aperiodic primary, L3, L4 the secondary, re-employed as a tuned-impedance coil in the plate circuit. This last inductance consists of two windings in series, the first L3 on the same form as L1 and L2, the second L4 on a smaller form which rotates within the larger. This inductance, therefore, has in tuning the effect of a variometer and thus elim-

inates the use of a third variable condenser.

Making the Coils

The coils needed (Fig. 2) are of cardboard or other dielectric material, the larger form 4" in diameter and 5" in axial length, the smaller of 3 1/4" diameter and 2" long.

Using a milk bottle form to secure a firm purchase on the coils (Fig. 3), remove their unessential portions (Fig. 4). A half inch from both the lower and upper edges of the larger coil draw circumferences around it. Next, at even intervals mark off 8 vertical strips 1/2" in breadth and extending from the upper to

the lower circumference. Remove the portions between the marked-off strips.

To make the smaller coil low-loss, draw two circumferences around the smaller coil, this time 3/16" from the upper and lower edges. Next at even intervals mark off 4 vertical strips 1/2" in breadth and extending from the upper circumference to the lower. Again remove the portions between the marked-off strips.

The forms are now given two coats of collodion or beeswax, after which they are wound as follows: Starting from the bottom of the larger coil leave 1/2" space and wind 38 turns of No. DSC Terminate. This winding is L1. Without leaving any space between, wind from where L1 was

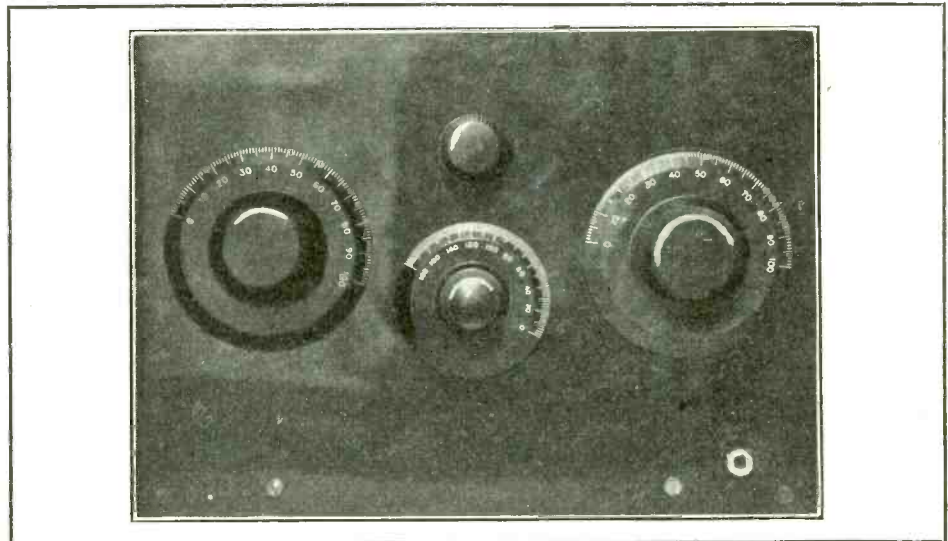

THE PANEL LAYOUT for the Ultra-Audion coupler. The left control adjusts the capacity reflex. The center control tunes the special between grid and filament. The right control is the wavetrapp.

Lindheim's Improved Reflex

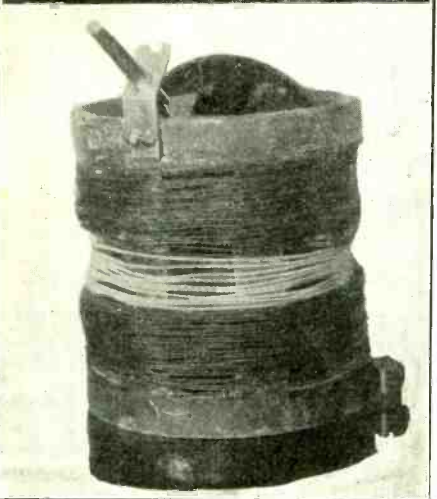
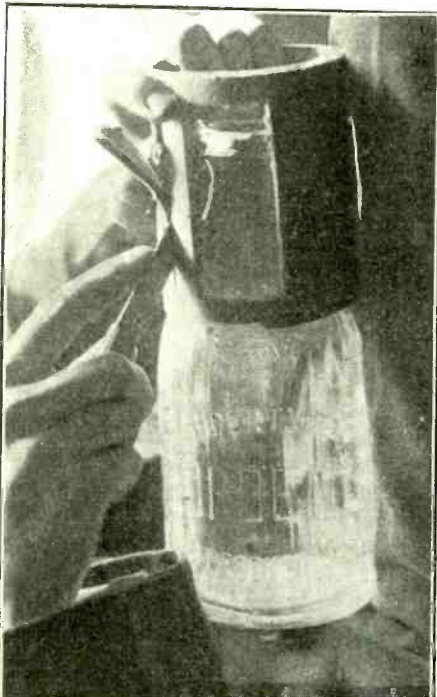

THE TUBING on which the stator windings are to be placed is cut away until only enough insulation is left to support the wire. A milk bottle gives a good purchase for the form during this cutting process. The lower photo shows the completed coil.

List of Parts

One special coupler.
Two .0005 low-loss variable condensers (C1 and 2).
One Bradleystat (R1).
One .002 fixed condenser (C3).
One Bretwood variable grid leak (R2).
One audio-transformer.
One single-circuit jack and plug.
Two 4" diameter dials.
One 3" diameter dials.
One terminal block.
One socket.
One tube.
One A battery.
One 45-volt B battery.
One 7x14" panel and cabinet.
Hardware.

terminated 12 turns of the same kind of wire. Terminate. This winding is L2. without leaving any space between, from where L2 was terminated wind on thirty turns of the same wire. Terminate. This winding corresponds to L3. The stator coil has then been completed. The top end of L3 is later connected in series with the rotor which has 30 turns of the same kind of wire running in the same direction.

It is not necessary to use the 180-degree coil mountings. The author obtained them from an old variocoupler. If the usual mounting is to be used, drill shaft holes through the top of the stator coil and attach the rotor by means of a brass rod. Bushings are inserted in the stator shaft holes and a pigtail connection between rotor and stator is made. The rod should not pass all the way through the interior of the form, but the shaft connections to the rotor are made just inside the rotor form.

The coupler used, therefore, is of the cut-out variety and those requiring more explicit details of its construction are referred to the January 17 issue of RADIO WORLD.

The Way to Mount Parts

The parts are then mounted. Drill the hole for the coupler in the middle of the panel 3" from the bottom. The coupler is also supported by a small bracket which is attached to the bottom of the

stator coil. Directly over the coupler 1 1/4" from the top of the panel mount the rheostat. Mount the two variable condensers 4" from the bottom of the panel and 2 3/4" from the sides. The phone jack is mounted in the lower right hand corner. If the parts are so mounted the front of the panel will have the symmetrical appearance.

The set is then wired. To avoid the added resistance attendant on soldering, No. 14 bare soft copper wire is used and the connections are made by looping and squeezing together with the pliers as in Fig. 9.

Wiring Directions

1. Connect the left hand condenser across L1.
 2. Connect the top of L2 to aerial binding post, the bottom of L2 to ground.
 3. Connect the top of L3 to L4.
 4. Connect the top of L4 to the ground binding post.
 5. Connect the lower end of L3 to the plate binding post.
 6. Connect the plate binding post through phone jack through B battery to P terminal of audio-frequency transformer.
 7. Connect the plate binding post also through C3 to the B terminal of the transformer which connect to A plus.
 8. Connect the grid binding post to the G terminal of the transformer.
 9. Also connect the grid binding post through the yet unconnected variable condenser (across which is shunted the variable grid leak), to the A minus.
 10. All that remains is to hook-up the filament circuit. After verifying connections previously made, connect A minus to rheostat and the other side of rheostat to filament terminal. Connect other filament terminal to the F post of the transformer. The set is ready to operate.
- Sometimes a potentiometer to control oscillation is found valuable. If necessary, this is connected across the A battery, the F post of the transformer going to the moving arm, the B post of the transformer going to the A plus side of the potentiometer.

The set is tuned as follows: Adjust to approximate wavelength with wave trap condenser C1. Control oscillations with other condenser and variable grid leak. The final adjustment is made with the coupler control which often necessitates retuning the entire set.

Sunning His Set Daily, Fan Gets Much Better Reception

SPEAKING of a study of static conditions in Latin America, where he recently visited, R. A. Lundquist, chief of Electrical Equipment Division, Bureau of Foreign and Domestic Commerce, Washington, D. C., said:

"It may be remarked here that my study of conditions in Colombia indicates that at least part of the so-called static interference met with was due to set noises awssphozETETSHR SHR H HHTTTH and to leakage resulting from poor maintenance of the distribution lines of light and power companies. Absorbed moisture is undoubtedly the cause of some of the trouble encountered, especially where high plate voltages are used. As proof of this, I was told by an electrical engineer in a Colombian city that a popular-priced set owned by him gave quite good results only after he made a practice of sunning it daily in order to keep down

the moisture. The humidity factor is often times aggravated by the prevalence of dust in some localities."

FOREIGN COUNTRIES BARRED FROM 300 AND 450 METERS

WASHINGTON.

NOTICE has been given by the Department of Commerce to foreign countries that the 300 and 450 meter wavelengths are now assigned to broadcasting stations and that attempts to use them to communicate with stations in this country must be discontinued. The 450 meter wavelength, however, may be used by ship stations in communicating with foreign compass stations.

A 3-TUBE REFLEXED NEUTRODYNE, by Percy Warren. Send 15c for May 16 issue, RADIO WORLD.

A Matter of Principle

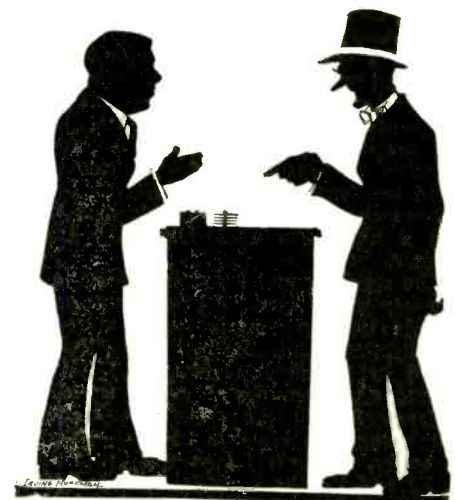

Customer—I want a battery, please.
Salesman—What make?
Customer—I don't care what make it is, but it must be a dry battery.

How to Make Your Set Tune the Entire Wavelength Band

By J. E. Anderson
Consulting Engineer

HOW can I extend the tuning range of my set so as to reach the entire wave length band?" is a question which fans are continually asking. Many questions come from fans who think their sets require special treatment. Sometimes they do, but not often. The tuning units in the various receivers are all alike in that they are composed of an inductance and a capacity. Usually the capacity is varied to adjust the circuit to different wavelengths. If the inductance is varied the set does require special treatment. Probably in more than 90 per cent of all receivers the tuning is done by varying the capacity.

The Causes and the Remedies

One complaint is that the tuned circuit has too high an upper wavelength limit. It is not necessary in a broadcast receiver to tune up to wavelengths higher than 560 meters. Also, the tuned circuit may have too high a zero setting capacity. And a third reason is that the ratio of inductance to capacity may be too high.

If the trouble is due to the set tuning too high just remove turns from the tuning inductance until the circuit tunes up to 560 meters and no higher. If the condenser is .0005 mfd., the correct inductance may be obtained with a coil having 45 turns of No. 24 double cotton covered wire on a tubing 3" in diameter. If the coils in the circuit is not of that type, it may be well to wind such a coil and compare the coils in the set with it, using the same condensers.

If Zero Equals Too High Capacity

If the trouble is due to too high a zero capacity setting there are many contributing factors. The first is the minimum capacity of the condenser itself. This has an average value of about 10 micro-microfarads. If the condenser is enclosed in a metal case it may be as high as 25. The second is the distributed capacity of the tuning coil. This varies widely for different types of coils, and it also depends to a certain degree on moisture. For a closely-wound solenoid the distributed capacity in micro-microfarads is about equal to the diameter of the coil in centimeters. It is independent of the length of the winding. If the turns are spaced the capacity may be about halved. Often the capacity is a little greater than this rule gives. It may be taken as about 10 micro-microfarads for design purposes. A third factor is the capacity of the leads to the coil, to the condenser, and to the vacuum tube. This, of course, depends on the length of these leads and their distance apart. This may be minimized when building the set, but it is difficult to change it after the set is already constructed. The value of this capacity may also be taken as 10 micro-microfarads.

A fourth contributory factor is the capacity of the tube as measured between the grid and filament terminals. This differs with the temperature of the tube and with the load on the tube, that is, with the kind of plate circuit which is used. It is also different for different kinds of tubes. I measured tubes giving values from 5 micro-microfarads up to about 30; and for special loads on the tubes the capacity has been very large.

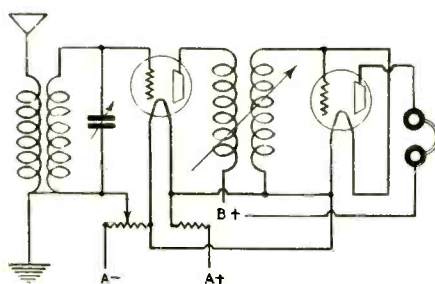

THE radio-frequency transformer in the aerial circuit should have 45 turns of No. 24 DCC wire on the secondary, ten turns on the primary. The variable condenser should be .0005 mfd. Then the whole wave band may be tuned in. But adjusting inductance alone (as in the coupling transformer between stages) is more difficult, as J. E. Anderson explains.

Ordinarily it may be taken as about 20 micro-microfarads.

Capacity Result, .00004 mfd.

If the capacities due to these four causes be added there will result a capacity of 40 micro-microfarads. For purposes of design it is well to add 10 more for good measure, so that the total is 50 micro-microfarads. I have measured a large number of typical input circuits and obtained an average of 34 micro-microfarads, exclusive of the capacity of the condensers at zero setting, which was 20 mmfd., making a total of 54. In these measurements the capacity between the leads was greater than they need to be in a finished circuit, and the zero capacity of the condenser was also greater than the average. Hence 50 may be taken as an average.

Supposing a minimum capacity of 50 micro-microfarads, let C stand for the capacity change which may be effected with the condenser, that is, let it stand for the difference between the minimum and the maximum capacities. Let C-O stand for the zero capacity as given above. Then the total capacity in the circuit when the condenser plates are fully meshed is C plus C-O, and the total capacity in the circuit when the plates are set for minimum is C-O. Then it may be shown by a very simple calculation that if it is desired to cover the range 550 to 200 meters, C-O must not be greater than .1523C, or C-O must not be greater than .1322 (C+C-O), or again, C must not be less than .56 C-O. These conditions are met if C=328 micro-microfarads. This is about the capacity change that may be effected with an ordinary 17-plate condenser.

Margin Is Not Safe Enough

But the above range does not give any margin of safety at either end of the scale. Suppose 10 meters is allowed at each end. Then the range which it is desired to cover will be from 560 to 190 meters. Calculation will show that C-O must not be greater than .13C, or C-O must not be greater than .115 (C+C-O), or again, C must not be less than 7.7C-O. These conditions will be met if C=385 micro-microfarads. A 17 plate condenser will not cover the range under the conditions assumed but there is no so-called 500 mmfd. (.0005 mfd.) condenser on the market which will not. Such a condenser may be considerably overrated and still be able to cover the range. The minimum capacity may also be considerably greater

than the value assumed without necessitating a larger condenser.

Where 30 Plates are Needed

Now suppose that it is desired to cover the range from 600 to 175 meters, a range claimed for many tuned circuits. Calculation will show that C-O must not be larger than .093 C, or it must not be larger than .085(C+C-O), or again, C must not be less than 10.77C-O. These conditions will be satisfied if C=539 micro-microfarads, or the capacity of the condenser should be at least 549. Probably there is no so-called 500 mmfd. condenser on the market which will cover this range, since the required C is about 10 per cent higher than the value usually found in condensers sold as 500 mmfd. instruments. A 43-plate condenser, or one of equivalent capacity, will, of course, cover the range and allow for large margins. If it is necessary to cover this range, and it is not desired to use a 43 plate condenser, it is possible to take one of these and remove some of the plates, say to about 30.

It is possible in many cases that the zero capacity is smaller than the one assumed above. Then the tuning range will be much wider than the one calculated. In a Super-Heterodyne circuit designed by me and built by a fan, the tuning range was from 187 to 560 meters, using a Hammarlund condenser and inductances of 45 turns of No. 24 DCC wire on bakelite tubings 3" in diameter. (See Radio World for May 31, June 7, and June 14.)

Solution Usually Simple

In most cases the range of the tuned circuits may be made to cover the broadcast range by simply removing turns from the inductance coils until the circuits tune up to 560 and no higher. If then the short waves cannot be brought in the remedy is to use a larger condenser and to re-adjust the inductance of the coil. In some cases the tuned circuits actually cover the short waves when the fans say that they cannot tune lower than about 278 meters. The trouble is that the tuning is too sharp. Not that the circuit is too selective, but it is merely difficult to separate the low wave stations. They are all crowded into a very small space at the lower end of the condenser scale, and a very slight change in the setting of the condenser is sufficient to detune the set. To pick out a station and hold it is like finding a needle in a haystack. The best remedy is to use a straight-line frequency or straight line wavelength condensers; that is, condensers which have specially cut plates so that the capacity change for a given angular change is very small at the low end of scale. There are several of these condensers on the market, some of which have simply stagger cut plates. If this type of condenser is used in the tuned circuits most of the trouble at the short wave end of the scale will be eliminated. If the ordinary condenser is equipped with a slow motion device it is not necessary to use the "straight line" type at all.

["The Ideal Coils," by J. E. Anderson, was discussed in the March 7, 14 and April 18 issues of RADIO WORLD. The directions for winding such coils for 23-plate and 43-plate condensers were given.]

GETTING BETTER QUALITY FROM AUDIO, by Brewster Lee. Last AF stage connected to two tubes in parallel. Send 15c for May 16 issue to RADIO WORLD, 1493 Broadway, New York City.

The 5-Tube Neutrodyne Set, With "One Lonely Dial"

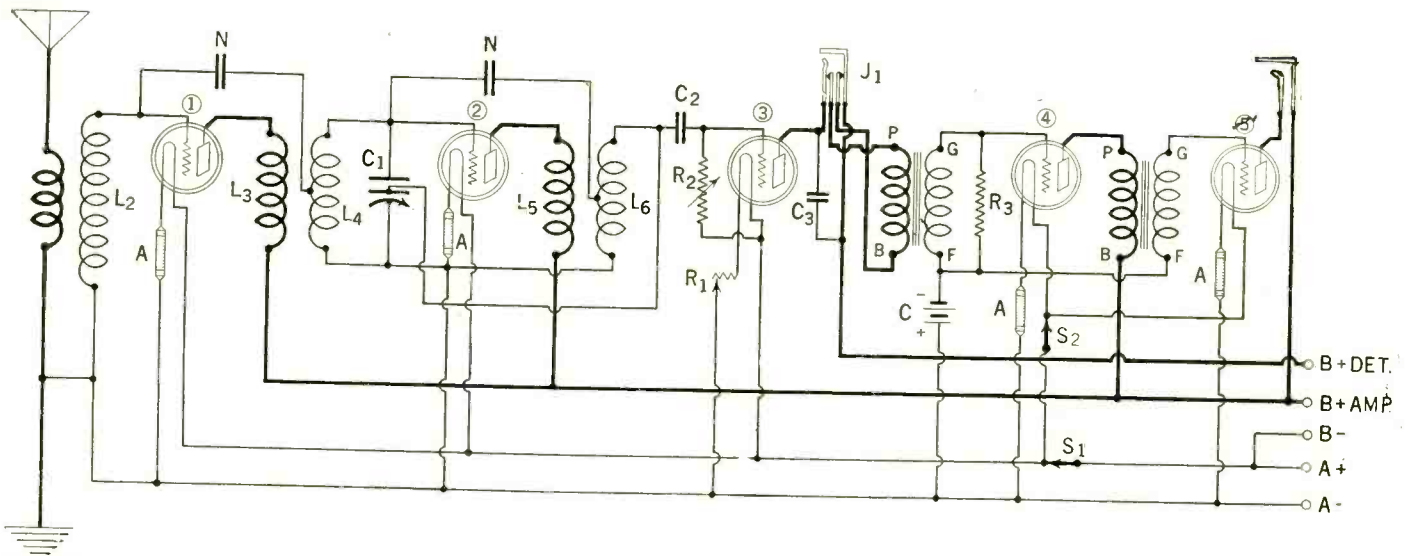

FIG. 1—Diagram of the 1-control Neutrodyne receiver. The first RF stage is untuned, a commercial transformer being used. The two other stages—second RF and detector input—are tuned by a double condenser having two separate stators and a common rotor, such as National, Flewelling, Bruno, Metric, etc. The tubes are numbered and are as follows: 1, first RF; 2, second RF; 3, detector; 4, first AF, and 5, second AF. This numbering is preserved in Fig. 2.

By *Sidney E. Finkelstein*

FOR THE past few years we have had all kinds of Neutrodyne receivers, e.g., three tubes with one step of radio-frequency amplification, a detector and one step of audio frequency amplification; three tubes doing the work of four with reflex action and the straight 5-tube affair, etc., but all these sets have had two or three dials. The tuning in all these receivers was not difficult, but required some attention. The three dials, which controlled the tuning condensers were supposed to read alike, viz., dial No. 1, 30; dial No. 2, 30; dial No. 3, 30, for a given station, but did not read alike on account of either poor neutralization or not enough turns on the radio-frequency transformers to balance them all or other considerations.

Here is a Neutrodyne with "one lonely dial."

First RF Stage Untuned

In this receiver we have the first radio-

frequency transformer untuned where the only real change from standard is made. That is done connecting the end of the primary of the transformer to the end of the secondary. This is for the purpose of getting louder signals on account of the transformer not being tuned, and it being difficult to get good results with loose coupling and no tuning.

The inclusion of the fixed RFT in the antenna circuit takes care of the problem of the usual first dial, at extreme left, running ahead of the others at one extreme of the reading, and behind at the other extreme. In other words, the second and third dials from the left usually tune in step in the regulation 3-control Neutrodyne, while the dial at extreme left does not. Just what the full reasons for this are has not been brought out. Some contributing factors are the capacity of the aerial-ground system, about 50 micro-microfarads, and which is not evenly communicated, if communicated at all, to the other stages, as well as to the fact that there is no tube plate in the antenna circuit that must be reckoned with, as to the effect of its capacity. The capacities of the two remaining plates, second RF and detector, may be assumed to be equal, for what variance there may be between these two would have no noticeable effect on tuning.

Ant. L2 is a commercial fixed radio-frequency transformer, (Werner No. 1

for 201A). L3L4 is wound on a form 3" in diameter and 4" long. From the top of the form, wind 12 turns of No. 22 DCC. Leave two ends or leads out for the plate and B plus connections. Leave 1/2 inch and wind 12 turns. Make a tap loop at this point and continue winding 33 more turns, total 45 on secondary. The beginning of the secondary winding goes to the grid and the end goes to F minus. Wind the other radio-frequency transformer (L5L6) in the same manner. After completing the winding, put some collodion on the ends of coils for holding purposes. Mount these coils on the back of the baseboard on small 3/4" angle iron.

Panel Layout

Lay aside the coils and take the panel which we will now drill. A 7x21" panel will just suit the purpose. Just 10 1/2" from the sides of the panel and 3 1/2 inches from the top of the panel drill the hole for the condenser shaft, which is 1/4" in diameter. Mount the other panel parts—rheostat, two jacks and two switches, where most convenient.

How to Wire the Set

Place all the instruments in their respective places. The five sockets are placed in a row. The audio-frequency transformers are put in back of the last two sockets, at right angles to each other, so as to prevent distortion. The radio-frequency transformers L3L4, L5L6, are placed directly in back of the RF sockets. Mount the two leaks right on the baseboard near the detector socket and the first AF socket respectively. The two neutralizing condensers N are mounted near the RFT. Place all the materials as near to the objects to which they are going to be wired as is possible, so that short leads will result. Bring the P or Ant. post of the first RFT to the Ant. post on the terminal strip, and the GND or B post of the first RFT to the GND post of the terminal strip. Connect the post marked G for the fixed RFT, L1L2, to the grid post of the first socket, at left, Fig. 1, and also to one post of the neutralizing condenser. Bring the last post marked F minus of L2 to the post marked



SIDNEY E. FINKELSTEIN

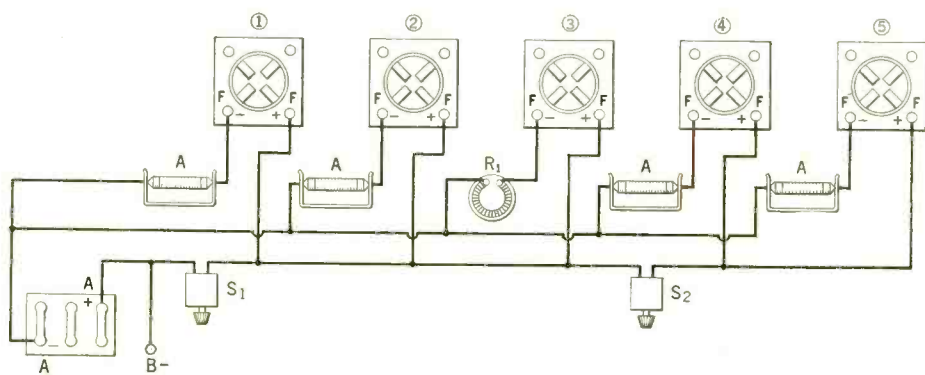

FIG. 2—How the filament connections are made. The mounts support A, (Amperites). R1 is the ohm rheostat for the detector tube. S1 and S2 are filament switches. The storage battery has six volts, 100, 110 or 120 ampere-hour capacity.

RF with No Extra Control

By Percy Warren

RADIO-FREQUENCY amplification, with its attendant strengthening of weak signals and enhancing of a circuit's reaching-out power, is very successfully accomplished without the RF stage occasioning an extra control (Fig. 1). The coil may be wound at home in a few minutes. On a 3½" diameter tubing, about 5" high, wind ten turns for the primary L1, 42 turns for the secondary, L2, and 35 turns for the tickler L3. Each winding is separate, of course, and one may be as close to its neighbor as it is possible to get it. The wire is No. 22 single cotton covered.



PERCY WARREN

All the connections are simple and easy, although some may find the method of coupling the RF stage to the detector rather novel. The grid condenser C3 is used for this purpose. One side of C3 is connected to the plate of the RF tube, the other side of that condenser to the grid of the detector tube and also to one side of the variable grid leak. If a fixed leak is used—and it will not usually give as good results as the adjustable type in this circuit—the resistance should be about 2 megohms.

How to Get Connections Right

Standing the coil form upright, for the purpose of illustration, with the aperiodic primary L1 on top, the connections should be made as follows: Ground to the top terminal of L1, aerial to the bottom terminal of L1; grid of the RF tube to the terminal of the secondary (upper) adjoining the end of the primary; end of the secondary to A battery minus; beginning of the plate coil L3 (end of wire adjoining secondary) to B plus amplifier, usually from 67½ to 90 volts, and the remaining terminal to the plate of the RF tube. Fig. 1 shows this correctly, although it might seem otherwise at first glance.

Take care that the rotor plates of both variable condensers go to low potential, that is, C1 rotor to A minus and C2 rotor to B plus.

The set may be logged, another fine advantage. It is selective indeed. There is no simpler and easier way of employing RF and producing a DX set.

Parts Easily Obtained

Almost everybody has a couple of variable condensers around the house. The form may be cardboard. The rest of the material is in the standard class and often represented by excess equipment at home. Therefore there is every incentive to try out this set. You won't be disappointed.

Any type of tube may be used, except the non-oscillating type in the RF stage. In the detector stage even a non-oscillator will work. This comes close to being an "any-tube" set.

No concern need be felt because there is no transformer to steep up the voltage between the RF and the detector stages. The presence of regeneration in the RF stage gives you all the amplification necessary. Indeed, there may be danger of over-amplification if transformer coupling were added.

No Trouble With Regeneration

The regeneration is doubly effective. This is a tuned plate circuit, also one in

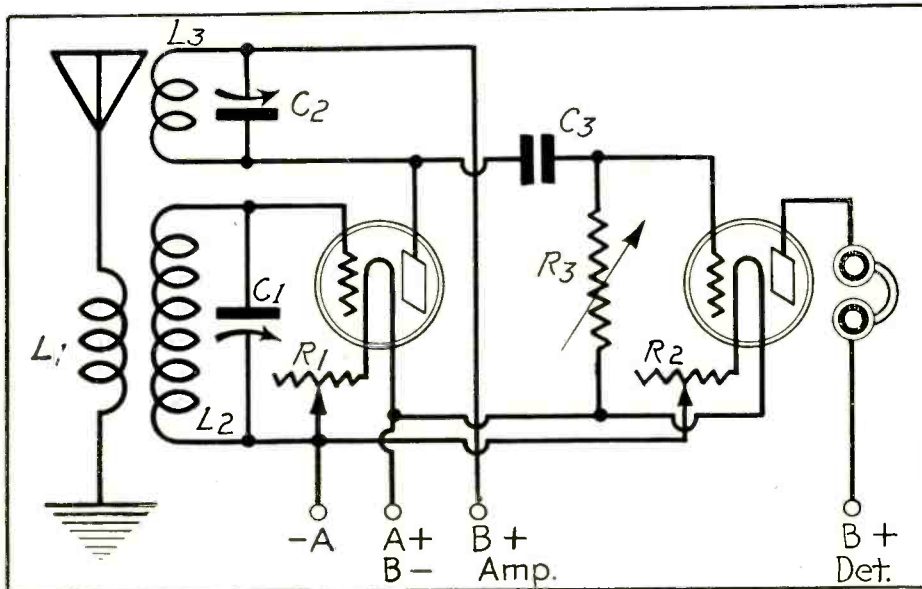

ONLY TWO CONTROLS in this RF amplifier set, yet it is a great performer. The hookup shows probably the simplest effective way of using a stage of RF ahead of a detector tube. The RF tube is regenerated and is coupled capacitatively to the detector circuit, the grid condenser C3 being used for this double purpose.

which there is inductive coupling between plate and grid. Some who have built tuned plate sets, where a variometer is in series with the plate lead, or a fixed coil is so placed, and tuned with a variable condenser, have not had a great deal of luck. This is due to the tube not being a good oscillator. With such tubes the rotating tickler coil is better. But in this circuit the inductive coupling makes regeneration just as certain as if the rotatable tickler method were used.

A Tip About the Leak

Notice that the grid leak is connected from the grid post of the detector tube to the A battery plus. Do not connect it across the grid condenser on mounting clips with which such condensers often are equipped. That would have the grid of the detector tube leak off to the plate of the RF tube, hence the B battery, which is no kind of leakage path at all for a respectable receiver.

If desired, the ground may be connected also to A minus. This would make the aerial conductively coupled, instead of just inductively coupled, to the secondary. Such change, however, scarcely makes any difference, at least none that can be noticed either in tuning effect or reception.

The rheostat R1 and R2 should be of the proper value for the tubes used.

List of Parts

- One tubing, 3½" diameter, 5" high.
- ¼ lb. No. 22 single cotton covered wire.
- Two variable condensers, .0005 (C1, C2).
- Two rheostats (R1, R2).
- One variable grid leak (R3).
- One fixed condenser, .00025 mfd. (C3).
- One A battery.
- One 45-volt B battery.
- One 22½-volt B battery.
- Aerial wire, lead-in wire, internal set connecting wire (No. 18DCC is great); ground clamp, lightning arrester, phones, tubes, sockets.

Tubes that work on 1½ volts are excellent for this set.

A SURVEY OF 1-TUBE DX SETS, by Lieut. Peter V. O'Rourke. Seven circuit diagrams. Great material for DX fans. Send 15c for April 11 issue. RADIO WORLD, 1493 Broadway, New York City.

THE BLUEBIRD REFLEX 2-tube earphone marvel by Capt. Peter V. O'Rourke. Send 15c for February 7 issue. RADIO WORLD, 1493 Broadway, New York City.

A Stage of RF Stabilized by Absorption

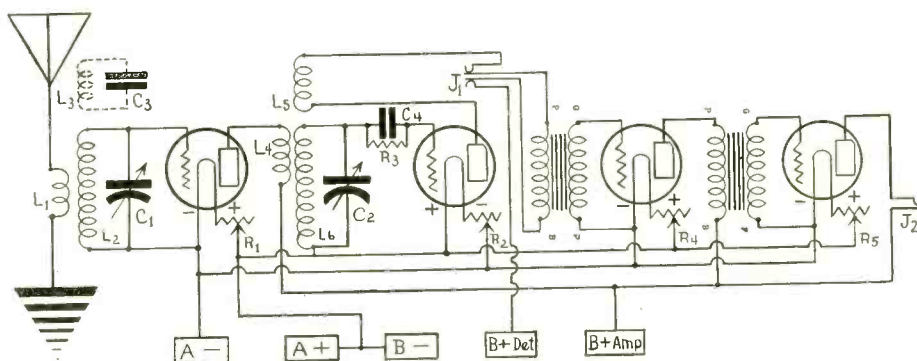

IF YOU HAVE two 3-circuit tuning coils, one may be used in an RF stage, the tickler L3 being shunted by a .001 mfd. fixed condenser C3 and varied until the best setting is determined. It is then left that way. L1L2L3 and L4L5L5 are the tuning coils. C1 and C2 are .0005 mfd. L5 is the regenerating coil or tickler. R1, R2 and R4 are rheostats, R3 the grid leak. C4, grid condenser, is .00025 mfd.

Wiring the 2-Control Diamond

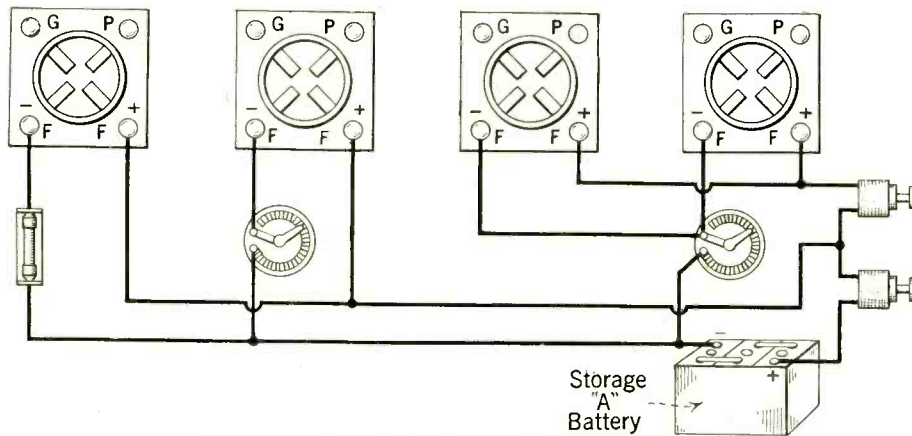

FILAMENT wiring of the 2-Control Diamond of the Air.

By Herman Bernard

THE ONLY difference between the 2-control Diamond of the Air as an outdoor aerial set and as a loop receiver is that the loop replaces the radio-frequency transformer. Those who desire to have a 2-control set that will work either loop or outdoor aerial have some work ahead of them, as the RFT and coupler secondaries must be matched and also the loop must be matched with the coupler secondary. While this is not impossible, it is a hard task, and one to be discussed another day. We will suppose that either the outdoor aerial set or the loop set is to be constructed.



Herman Bernard

Matching the Coils

Take the outdoor aerial set, discussed in last week's issue of RADIO WORLD, (May 23). The only difficulty that need be expected is in the matching of the coils. Ordinarily the same number of turns on the secondaries will do the trick, and I presume this is what manufacturers mean when they refer to matched coils. But it is possible that the same number of turns on primaries and secondaries will cause a given condenser setting to represent different wavelengths. Why?

Look at the circuit diagram, Fig. 1, last week's issue. The aerial has capacity and inductance, all of which are contributed (along with resistance) to the first or RF tube. All these are taken care of by that tube, which is also affected by the same contributing factors of L1 and L2. Now, if conditions were always identical for L3L4 as for L1L2 there would be nothing to discuss on the subject of matching. But L3 is affected by the capacity of the plate of the first tube, an effect it passes on to L4. Also both L4 and L5 are affected by the tickler L5, the action of which, when there is tight coupling, is to extract from L4, and to a tiny extent even from L3, some of the inductive value that the tabulations would lead you to believe L4 possessed. The tight coupling does not refer to the rotative position of the tickler so much as to the actual position of the tickler in the construction of the coil. Thus, if the tickler were 2" or more away from the stator at the nearest points, this would be loose coupling, no matter if the tickler were rotated so its windings were parallel with the stator windings. In such an instance of loose coupling the absorption effect of the tickler would be nothing

worth reckoning with, but in most 3-circuit coils made commercially or at home relatively tight coupling exists. Hence some allowance should be made for the diminution of inductive value in the interstage coupling. Also, the grid condenser has an effect, so that these, plus the resistance of the leak, leave something to requiring attention.

Not a Great Difficulty

It must not be supposed that the solution is a frightful task. The receiver is such a splendid one that even considerable work would reap a worthwhile reward Offhand, considering a tightly coupled tickler, plate capacity and other elements, it would be fairly safe to start with a secondary that has two turns more than the secondary of the RFT. If the coil is home-made, it is an easy matter to wind the extra two turns, try the set out that way, if trouble arises remove one turn, if trouble persists, remove the other. With commercial coils it would be simpler to remove a turn, then, if necessary, another, from L2; leaving L4 intact. But, as was said before, if you have two secondaries of identical number of turns, try them out just as they are. The likelihood is that you will not experience non-resonance, provided the double condenser is a good one. It should not have any great leading and lagging tendencies, whereby the capacities represented by respective settings are much different as to one side of the condenser and the other. Absolute uniformity throughout is not to be expected, nor is it necessary. A maximum variation at any point of .00006 would not cause any noticeable difference, nor affect tuning. Sometimes one condenser at one point will be greater in capacity than the other, while at other points the one that formerly was of higher capacity will be lower in respect to the other. So long as this leading and lagging and interchange thereof is infinitesimal there can be no harm, and the fact of its minute existence should not deter anybody from employing this type of condenser. Actual tests made with the Velvet Vernier National, the Bruno, the Flewelling and the Metric proved that they stood the test very well.

Use of .0007 Type

The condensers prescribed have a total capacity of .001 when in parallel. Each of the two sections is .0005 mfd. maximum. The parallel connection is not used. Those who may have on hand a double condenser of .0007 mfd., normally 34 plates, each of the two sections .00035 mfd., or 17 plates, may use that in the circuit, but must have coils with about 10 more turns on the secondaries. There is greater assurance of covering the wavelength belt of

the broadcasting stations by using the larger capacity condenser, since the other requires too close figuring, and if conditions are not just right—a little too much stray capacity here, or distributed capacity there—you are out of luck.

The A Battery Wiring

The filament wiring should be done first. This is shown in the picture diagram, Fig. 5. All the resistances are in the negative leg. This supplies a slight negative potential to the grids of the amplifier tubes, augmented of course by the negative biasing by the C battery, applied to the two audio tubes. In the detector circuit this negative bias is overcome by the method of connecting the grid leak (to A positive). The tubular ballast resistance on a mounting at left is the Amperite which should be the right kind for the tube you will use here. The fact that you are using an Amperite here helps a lot, in that you may use either a 5-volt RF tube or the 3½-volt tube, the Amperite being the one delivering 3½ volts from a 6-volt source. Many who prefer the 199 type of tube for RF may thus use it here although a special socket is needed. However, the equivalent tube, the DV3, fits the standard socket. Normally, however, the UV201A, the C301A or the True Blue tube would be used here. The rheostat in the detector tube is clearly shown in Fig. 5, as to its circuit position. The other rheostat, controlling both audio tubes at once, for they are not critical, will light and turn off the audio tubes, hence the second A battery switch (top, right, Fig. 5) may be omitted, and is included only as a convenience, it being easier to operate the switch for the purpose than tampering with the rheostat each time you want to tune in. That convenience can not be safely applied to the detector tube, as filament heating in that place deserves special consideration.

In looking over the filament wiring diagram it is well for the novice to notice where the A minus lead goes, as distinguished from filament minus. A minus represents the minus post of the storage battery. Filament minus represents the minus potential of the storage battery less the drop in the rheostat. Hence, the grid returns of L2 and L4, as well as the C plus connection, must be to negative A, or minus 6 volts, and not to filament minus, normally minus 5 volts. If that injunction is not observed not only is the resistance of the rheostats and ballast device included in the radio part of the circuit, but the 1-volt negative bias impressed through utilization of the rheostat voltage drop is lost. In the RF tube, for instance, in Fig. 5, F minus is represented by the upper part of the mounted resistor. A minus by the lower end. The detector rheostat is minus 5 volts at the upper (filament) point and minus 6 at the lower (A battery) point.

No such distinction exists as to the A plus, for it is identical with filament plus, there being no intercepting rheostat. Connect A plus to F+ of all four tubes.

The connection to the grid leak may be made just after the A circuit wiring, although this will be treated again.

Coil Wiring

Note in Fig. 3, published last week, that the RF coil is mounted on the baseboard, at right angles to the panel, also at right angles to the coupler. The connection from aerial leadin, through the terminal block, should therefore be made so that the terminal of L1 nearer back of panel goes to aerial, the other L1 terminal jointly to the beginning of L2, to ground

Aerial or Loop Gets Fine DX

and to minus A and to the rotor shaft of C1, while the remaining terminal of L2 goes to the grid of the first tube and to one of the stator posts of C1. In connecting the interstage coupler, do this after the grid condenser C2 and the leak are in place and wired. The leak connects A plus, at the most convenient point, and the G post of the detector tube socket.

Now connect the grid condenser being affixed to the G post, the other side is connected to the nearest terminal of L4. The only precaution necessary is that adjoining terminals be of the same relative potential. Suppose the stator (containing L3L4) is figured with the primary on top, secondary below, standing upright. If the top of the secondary went to grid, then the adjoining terminal of the primary goes to plate (likewise a high potential). The other polarities take care of themselves. If the grid is connected to end of secondary, then the beginning of secondary goes to ground, etc., and the end of the primary adjoining that goes to B plus, which is low potential, as is ground. Hence connect the plate to one terminal of L3, as outlined, the other terminal to B plus amplifier, usually 90 volts. One terminal of L4 is connected to the grid condenser, the other terminal to A minus, hence automatically to the rotor of C1.

The Audio Stages

The plate of the detector tube connects to one terminal of the tickler L5, the other end of which goes to the P post of the first audio-frequency transformer, the other terminal of L5 goes to one side of the fixed condenser C3, .001. The other side of C3 goes to one side of C4, .002, while the remaining side of C4 connects to

List of Parts for the 2-Control Diamond

- One radio-frequency transformer, L1L2.
- One 3-circuit coupler, L3L4L5.
- One double condenser (two sections, each .0005 mfd.) C1.
- One ballast resistance, R1, matched with tube you will use.
- One 20-ohm rheostat, R2.
- One 10 or 15-ohm rheostat, R3.
- One A battery switch, S1.
- One A battery switch, S2 (optional).
- Four sockets.
- Four tubes.
- Two vernier dials.
- One terminal strip.
- One .00025 mfd. grid condenser, C2.
- One variable grid leak, R4.
- One fixed condenser, .002, C4.
- One fixed condenser, .001, C3.
- One 100,000-ohm fixed resistor, R5.
- Two audio-frequency transformers.
- One single-circuit jack, J.
- 65-foot aerial, No. 14 insulated lead-in wire, lightning arrester, ground clamp, A battery, two 45-volt B batteries, one 4½-volt C battery, cabinet.

coupler secondary. If you use a commercial loop you must match L4 to the loop, with one exception. That is a tapped or otherwise variable loop. A good one to use is the Werner collapsible type, which can be made of less than maximum inductance simply by pushing it flatter. Coils wound as directed will be within the inductive scope of this loop.

* * *

Pastor Picks Diamond As His Pet Set

EDITOR RADIO WORLD:

KNEW nothing about radio and was not interested in it until one day, because there was nothing interesting on the news counter, I bought RADIO WORLD, December 27, and began to read. Here was something I did not know and it challenged me. I bought a few parts and built the Superflex. It was only a poor success. A friend advised me to try Bernard's Three-Circuit Tuner of November 8, and gave me the paper. I built it and it was fine. Then after about a week, I made a tickler, mounted it on a block, and hooked up the three-tube Superdyne, which was still better. I had been using tubes at \$1 each. Next I bought a Sodian D21 and two Magnatrons 201A which was another improvement and the quality was fine.

About a month ago, having a few evenings free, I put clips on condenser terminals and socket posts and decided to have some fun. With another socket and one of the cheap tubes I hooked up Capt. O'Rourke's Four-Tube D-X set (March 21). Results were splendid. After a few evenings I wound a primary around the plate coil, switched the tickler and hooked up the 1925 model DX wonder with two condensers instead of one. Volume and tone were superb. Then came the number publishing the Diamond. I hooked up that circuit and lost nothing. The next evening after the family was in bed, I hastily constructed a loop frame, used No. 20 DCC wire and slipped the ends in the clips on the condenser. The second station found was WSMB, New Orleans, a straight line of 780 miles. That was the Diamond on a loop. It was that station's inaugural program and came in clear and loud enough to be heard through two rooms. We have had it many times since and just as good. Other stations we can get easily on the loop are KDKA, 520 miles; KOA, 620 miles; WFAA, 650 miles; WGY, 760 miles. Last night I came in about 10 o'clock and turned the dials, picking up WOAL, San Antonio, 870 miles straight away, dedicating a new super-power plant. For 45 minutes I listened to two addresses and a band, every word and tone clear as a bell and strong enough to be heard anywhere in a radius of 20 feet. Then I thought I would try the low wave section and picked up KPRC, Houston, 800 miles away, not so loud, but easily heard through my study.

You will laugh at my parts, the cheapest I could buy. Apart from the speaker, the most expensive part was the panel, \$1.25, until I bought the three tubes mentioned above. I am still using the .0005 mfd and .00025 mfd condensers specified for the Three Circuit Tuner You Can Log. However, I do not advocate the cheap parts for a permanent hook-up. I am assembling better equipment and intend to build a Diamond to keep. I have learned what I can do, and at very little cost I'll have an experimental set to keep

(Concluded on page 31)

A battery minus. The end of the primary of the first AFT, marked B or P2, goes to B plus detector voltage (22½ or so). Across the secondary of the first AFT, especially if a General Radio, Federal, Stromberg-Carlson or other high amplifying transformer, is placed a 100,000-ohm resistor (1/10 meg. leak). The G or S1 post of this AFT goes to grid of the third tube while the F post goes to C battery minus, which lead also is connected to the F post of the second AFT. C plus connects to A minus. The plate of the third tube is joined to the P or P1 post of the last AFT, the B or P2 post goes to B plus amplifier, while the G post is joined to grid of the last tube. The F post already has been connected. The plate of the last tube is connected to the spring of the single-circuit jack, the right angle of which goes to B plus amplifier voltage. Hence, B plus amplifier voltage connects to three places, (1) one side of the jack, (2) the B post of the first audio transformer, and (3), the low end of L3 (to plate of RF tube). This may be made as a single lead in one operation.

The 6-Volt Difference

Try out the tubes. See if they light when the rheostats are turned on. If everything seems rosy, then connect A plus and B minus. That connection adds the voltage of the A battery to the voltage of the B battery, hence, if the storage battery is 6 volts, the 22½-volt post on the B battery block is really 28½ volts. The B battery voltage therefore may be decreased the amount of the A battery voltage by connecting B minus and A minus, instead of B minus and A plus. But, this is not recommended, as the A battery voltage may as well be used, so long as thereby you can get a correct B voltage for your detector and amplifier tubes.

The Loop Set

Wiring the loop set is done in exactly the same manner, except that the RFT is omitted and the loop connected to A minus and grid of the first tube. If you make your own loop, match it to the

This Nameplate FREE



A BEAUTIFUL colored nameplate to put on the panel of the Diamond of the Air will be furnished free to all. Send in your request to Name Plate Editor, RADIO WORLD, 1493 Broadway, New York, N. Y. The following are among the new applicants:

- Lester S. Byrd, 304 E. 15th St., Fort Worth, Tex.
- Roy Milton, 5735 Princeton Ave., Chicago, Ill.
- J. E. Hudson, 1403 E. Elm, Fort Scott, Kansas.
- Sgt. Thomas F. Johnston, Box 45, Fort Monroe, Va.
- Benjamin W. Martin, 216 61st St., Brooklyn, N. Y.
- Harry G. Sashko, 4712 Behwald, Cleveland, O.
- Chelsa Flack, R. D. L. Smithton, Pa.
- Henry H. Tonking, 52 Elliot St., Dover, N. J.
- Charles Meches, 38 N. Fifth St., Copley, Pa.
- Mr. Harold Jones 431 South St., Slatington, Pa.
- Y. O. Gordon, Jr., Albion, Me.
- Robert Schloss, 5127 Hunter Ave., Norwood, O.
- Harold Conklin, 1385 Bernard Ave., Outremont, Quebec, Canada.
- H. A. Simmonds, 141 Springs St., Carbondale, Pa.
- Walter H. Gray, 313 Locust St., Yankton, S. D.
- Robert Everd, 610 Patterson Pk., Baltimore, Md.
- H. E. Flack, 1821 Wilson Ave., Chicago, Ill.
- Omer Wilson, General Delivery, Emid, Okla.
- Jos. Hernandez, 340 W. 21st St., N. Y., N. Y.
- Frank Komok, 1315 First Ave., N. Y., N. Y.
- Claude Moring, Box 627, Plano, Ill.
- C. M. Hicks, 3969 Flad St., St. Louis, Mo

A 1-Tube Volume Reflex

By Capt. P. V. O'Rourke

THERE have been a great many reflex receivers, employing any amount of tubes, but some were found not to come up to the expectations. Some of these receivers have had untuned radio-frequency transformers in the reflexing stages. The receiver that I am going to describe (Fig. 1) has a tuned radio frequency transformer. True, the tuning is more difficult, but the reception as far as volume is concerned is nearly doubled as compared to some 1-tube reflex sets.



CAPT. O'ROURKE

Reflex sets are not very easy to get working right, the main troubles lying in the crystal detector and in the RFT, resulting in broad tuning and howling, but in this set we can tune the radio-frequency transformer and sharpen up the tuning without losing any of the volume that the reflex receiver is so well known for.

The Instruments to Use

A UV201A is used for the amplifying action. A fixed crystal detector is used for rectifying. To control the amplifier a rheostat (circle) is used. The audio-frequency transformer used is of high ratio. The tuned radio frequency transformer is manufactured by the Boonton Rubber Co., Boonton, N. J., and is called the Ballantine Radio-Frequency Transformer. C1 is a .0005 mfd. variable condenser. C2 is a .001 mfd. fixed condenser and C3 is a .002 mfd. fixed condenser. A 6-volt storage battery or four 1½-volt dry cells in series are used to light the filament of the tube. About 67½ volts are used on the plate of the tube. A 7x10 in. panel will house the instruments. A terminal strip holds all the connections from the external points of the set.

Coils for the Set

In the first RFT, L1, has 11 turns wound on a 3 in. diameter tubing with No. 22DCC wire. The secondary L2 wound in the same direction, has 50 turns and is ¼ in. away from L1. The same kind of wire is used. For those who wish to make a radio-frequency transformer like the Ballantine, the following data are given: Take a piece of hard rubber tubing 4 in. in diameter, 4 in. long, this being for the primary or stationary winding. Wind 50 turns of No. 36 SCC. Do not terminate. Leave ¾ in. and continue to wind 50 more turns in the same direction. The space left is for the shaft which passes through the center of coil and is ¼ in. in diameter. Leaving two leads protruding, the beginning and end, one for the plate and for the B plus.

Get another piece of hard rubber tubing 3 in. in diameter and 3 in. in length.

Stand the coil form up. Pick out some point on the top circumference. ¼ in. to the left of that point and also ¼ in. to the right of that same point make two marks. Disregard the center point, which was used only for guidance. ¾ in. to the left of the left-hand final point, scratch another point on the circumference. ¾ in. to the right-hand side do likewise. Measure down ¾ in. from the top circumference, registering three or four points as a guide and scratch a circumference at this level all around the form. Now with a saw, cut four little notches,

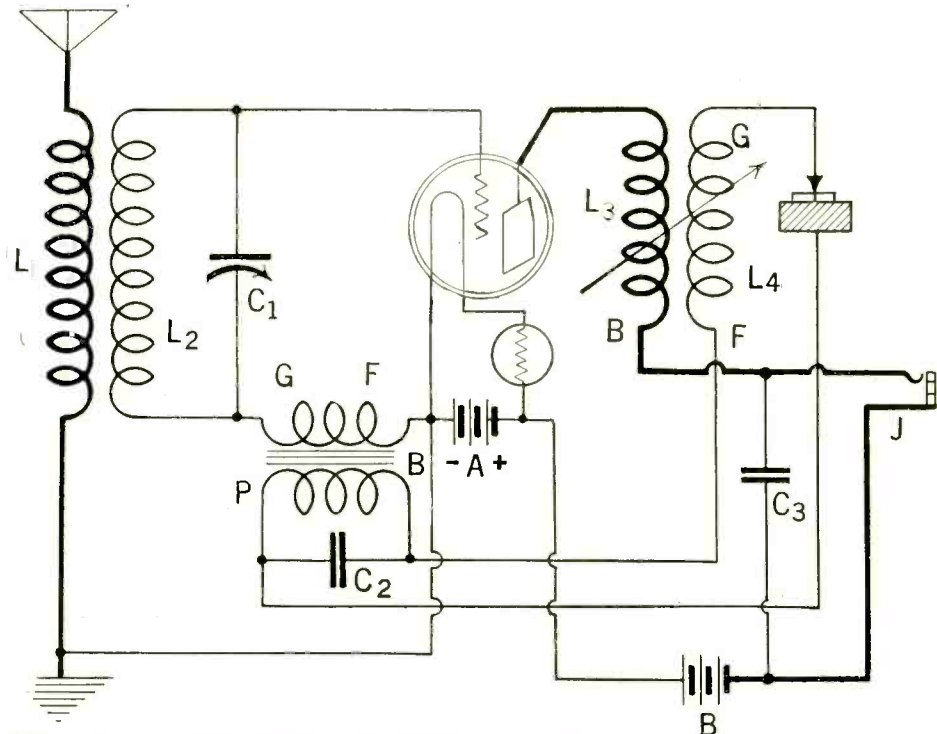

FIG. 1 shows the wiring diagram of the Ballantine Super-Volume Reflex. The resistance inserted in the positive lead of the filament is a rheostat. The plus side of the B battery goes to the frame of the single circuit jack and the negative side of B battery goes to the plus of A battery. In L3 the post opposite G which is connected to plate, may be marked P.

representing four points at the top circumference that were marked off, and also automatically notching the rear semi-circumference, eight notches in all. The object is to cut out four sections, two front and two back. The sawing is done more conveniently at an angle of 45 degrees to the plane, therefore, saw for a perpendicular result eight times, each to the depth of the ¼ in. as marked. To remove the ¾ in. squares, drill small holes close together for ¾ in. width to enable you to break off the excess at each of the four places. Smooth the horizontal with a file.

At the bottom circumference repeat the above operation in alignment and the result will be eight slots, four in front (two top and two bottom) and four in back. In the slots the wire is to be wound.

Now wind 50 turns No. 36 SSCC wire in one pair of slots, up and down. Do not terminate. Continue winding 50 more turns up and down in the other slots and leave an end sticking out. This makes a total of 100 turns, the same amount as on the stationary coil. 1½ in. from the edge on the slotted rotor coil, between the windings, drill a ⅝ in. hole. Between the halves of turns on the stationary coil, 2 in. from edges drill a hole ¼ in. diameter for shaft. Pass a piece of brass tubing 5 in. long through these holes. Solder a bushing on both ends which protrude through the coils, so as to hold the shaft.

The Panel Layout

There are two dials on the front of the panel, the condenser dial and the crystal detector dial, not counting the rheostat knob. The dial of the tuned RFT is inside the cabinet. There are only three settings (200-300; 300-400; 400-550) and therefore these do not necessitate any panel control.

The condenser dial is in the center of the panel. The crystal detector dial is about 2 in. in diameter and at the right hand corner, 1 in. from the bottom and 5 in. from the end of the panel. The

rheostat dial is placed at the left-hand corner in line with the crystal. The jack is at the left-hand corner.

Place the tuned RFT very close to the socket so that there are very short leads. The AFT is placed at right angles to the RFT and near the terminal which is located at the extreme left of the base-board. The other instruments are placed according to your own judgment.

The Internal Wiring of the Set

Bring the end of L1 to the antenna post and the beginning of the coil to the ground, which in turn goes to the A minus. The beginning of L2 goes to the stator plates of the variable condenser and to the grid post of the socket. The end of the coil goes to the G post on the AFT. The F post of the AFT goes to the A minus of the socket which in turn goes to the A minus of the battery. The plate post of the AFT goes to the crystal and to one point of the .001 mfd. fixed condenser. The B post of AFT goes to the F post of L4, the G post of L4 goes to the catwhisker. The beginning of the tuned RFT (L3) goes to the plate post of the socket, while the end of the coil goes to the jack and to one end of the .002 mfd. fixed condenser. The other end of the condenser goes to the B plus. The other connection of the jack goes to the B plus also.

What to Expect and How to Expect It

You will get best results if you use best parts. This set is not a distance getter but it is a volume producer on all the stations, local or distant. If the set howls, reverse the connections of the secondary of the AFT, and also the secondaries of the RFT. Be sure that the crystal is good. Test it with a pair of phones and a dry cell and see if it is sensitive. Hook up the phones in series with a 1½ volt dry cell and the crystal and if you do not get a click at nearly every point where the phone tip is placed on the crystal, then the crystal is no good. Also do not forget to reverse the A battery for possibly getting louder signals.

WHAT YOU SHOULD KNOW To Get Maximum Efficiency

Causes and Effects of Inductance, Capacity and Resistance Reviewed—Vital Questions Answered

By Lewis Winner

Radio Engineer

AT the end of each of three previous articles on resistance, capacity and inductance, there appeared a set of questions, which were supposed to have been answered after you had finished the reading of the articles. Here is a complete set of the answers:



Lewis Winner

Resistance

1—How do radio-frequency currents travel in a conductor?

They travel on the surface.

2—What is the effect of radio-frequency resistance on a tuned circuit?

It broadens the tuning.

3—What are the causes of radio-frequency resistance in a coil?

Not large enough wire (diameter), too close windings (jammed) causing eddy currents to flow (heating of wire); poor form that wire is wound on; poor soldering when connecting the coil.

4—What are the causes of radio-frequency resistance in a variable condenser?

Poor conductivity of the plates, poor dielectric medium and end plate losses, due to poor insulation.

5—Is the quantity termed radio-frequency resistance an actual resistance or is it a condition of leakage of energy which results in loss of the same amount of energy as would be lost were there an actual resistance in the circuit?

It is a condition of leakage of energy which results in the same amount of energy as would be lost were there an actual resistance in the circuit.

6—What is the formula for computing resistances in series and in parallel?

See Fig. 1.

Capacity

1—What is capacity?

Capacity is the property of any conductor which stores or accumulates energy in electrostatic form.

2—Where does it occur?

It occurs in coils, condensers, electron tubes, jacks, transformers, batteries, insulators, phone plugs, sockets, etc.

3—What governs the amount of capacity in a condenser?

The capacity of a condenser varies directly as the area of the opposed surfaces and the power of the dielectric to conduct the electrostatic lines of force and inversely as the separation of the plates.

4—What are a variable and a fixed condenser used for?

A condenser is used for tuning the secondary circuit in resonance with the primary circuit. It also may be inserted in series with antenna for decreasing the fundamental wavelength of the set. A condenser shunted across the antenna and ground increases the wavelength of the set. A fixed condenser is put in series with the grid of the detector tube for charging and discharging the charge built up in the grid. When shunted across the B battery a fixed condenser by-passes

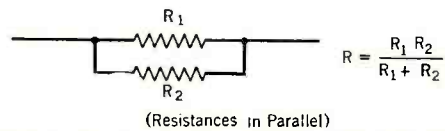
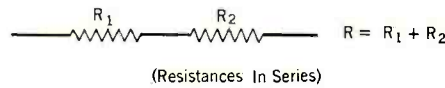

FIG. 1—How to calculate resistance. Note that the calculations are done in opposite manner to those for capacity.

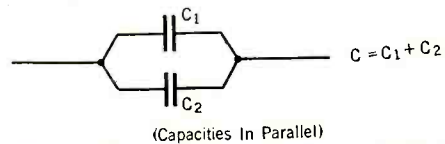
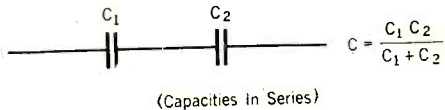

FIG. 2—How to calculate capacity is shown in the above diagrams. Capacities in series reduce the number plates connected up, while capacities in parallel add up the number of plates.

high frequency currents. A condenser across the primary of the audio-frequency transformer smoothes out distorted music in the amplifiers. A condenser shunted across the phones by-passes high frequency currents and allows louder signals to be heard (this is experimental and does not work out in some sets on account of the current being already by-passed by some method in the receiver).

5—Can we have capacity elsewhere than in a condenser?

Yes, in a coil of wire, between the turns of wire.

6—What is the formula for the computing of capacity of condensers in parallel and in series.

See Fig. 2.

Inductance

1—Where does inductance occur? Why?

Inductance occurs in every electrical circuit, because every circuit has wire and this wire in some manner or other stores up energy in electromagnetic form.

2—What governs the amount of inductance in a circuit?

The diameter of wire, length of wire, conductivity of wire, whether it is coiled or straight and the form on which wire is wound. The objects surrounding the wire (condensers, transformers, etc.) also are factors. If you want to calculate the actual inductance of a coil, it has to be disconnected from rest of the set. The formulas for such computation are found in the Bureau of Standards Circular No. 74, Radio Instruments and Measurements; 60c, from Superintendent of Documents, Government Printing Office, Washington, D. C. It is a complicated subject.

3—Describe induction in detail.

Self-induction is that remarkable feature which results from the rise and the fall of a large magnetic field of force around a circuit or coil, through which a current is flowing. When we induce an electromotive force in one of the coils, through which current is traveling and changing at a definite rate per second, provided it is not greater than unity, we have what is known as mutual induction. For

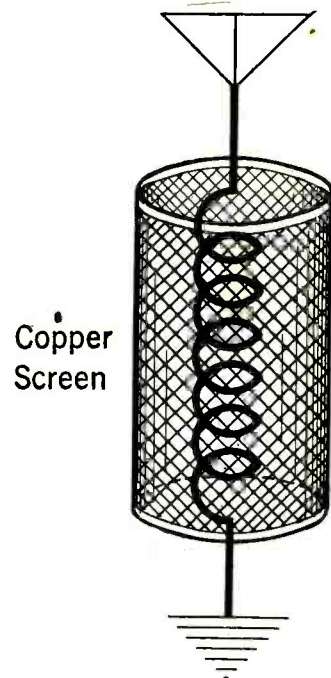

FIG. 3—The best ground that one can have is shown above. Note the large iron pot which is kept damp by the moist earth surrounding it. The wire is No. 14 rubber insulated. This ground can also be used for connecting up the lightning arrester, where the set is grounded to the cold water pipe. A good ground means less high-frequency resistance.

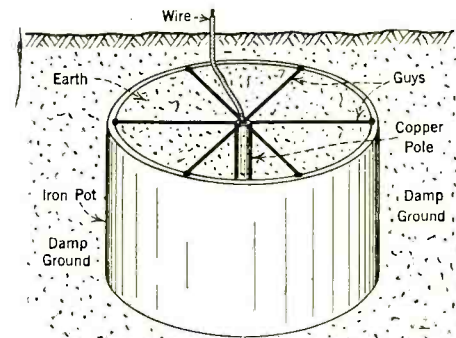

FIG. 4—A properly shielded antenna system, to be used in places where there are many antennas and a great deal of radiation takes place. The copper screen is 1/2" in diameter and covers the entire lead-in and ground (provided of course that the ground comes from the earth up to the house and not from a subsidiary ground connection in the house proper). There is an electrostatic field between aerial and ground, hence the above illustrates mainly a capacity effect.

instance, we have self-induction in the wire itself, but we have mutual induction when we have two or more wires, that is the current is induced from one wire to the other wire.

4—Can we have inductance elsewhere than in a coil?

Yes. We have inductance present in every electrical circuit, viz., in the motor, in the generator, in the spark coils, in the various meters (galvanometers, ammeters, voltmeters, radio-frequency meters, milliammeters, thermo-couple ammeters, wattmeters, inducto-meters, wavemeters, resistance meters, audibility meters, decimeters, vacuum tube testing meters, etc.) in the variable condenser, in the transformers, in the antenna, in the ground, in the counterpoise, in the thermionic tube, in the jacks, in the coils, in the

(Concluded on page 26)

THE RADIO UNIVERSITY

A QUESTION and Answer Department conducted by RADIO WORLD for its Readers by its Staff of Experts. Address Letters to The Radio University, RADIO WORLD, 1493 Broadway, New York City.

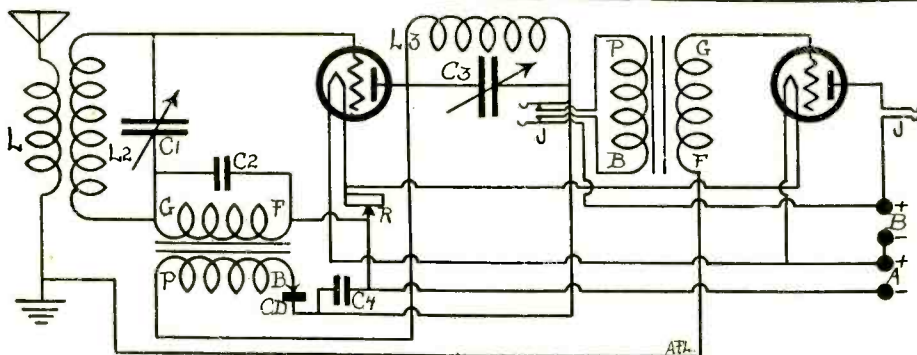

FIG. 150, the wiring diagram of a 2-tube reflex that operates a loudspeaker. There are only two controls, C1 and C3, both .0005 mfd. variable condensers (normally 23 plates). The R.F. transformer LL2 consists of two windings, both on a 3" diameter tubing, 4" high, spaced 1/4" from each other. L has 10 turns of No. 22 DCC wire, L2 has 43 turns. The only other tuning coil is L3, which consists of 45 turns of the same kind of wire on a 3" diameter tubing 3" high. C2 should be of very small capacity, .0001 or so, but if the circuit works well without that condenser, omit it. C4 is .002 mfd. The crystal plates to grid. Likewise the stator plates of C3 go to plate. If two different ratios of audio-transformers are used, the higher goes in the first stage (lower left in diagram). C3L3 supply regeneration.

PLEASE publish diagram of a 2-tube reflex, using crystal detector, that will operate a speaker.—James Force, Madison, Wis. See Fig. 150.

COULD I use the Acme audio-frequency transformers in the Diamond of the Air? (2) Would I get better results by employing the Morrison Static reducer, instead of the Sodian tube in my detector socket?—Joseph Pilizzi, 1305 Beuna Vista Ave., Alameda, Cal. (1) Yes. (2) No.

PLEASE show diagrammatically how to connect a C battery in a tuned radio-frequency stage for positive bias to control oscillation.—Lester Funk, Darien, Conn. See Fig. 152.

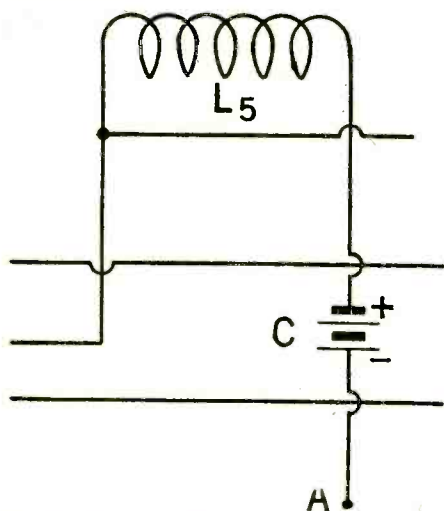

FIG. 152, how a C battery is inserted in a tuned or untuned RF stage. The tuning condenser is omitted, but would be across L5, representing the secondary. The end of L5 (at right) which ordinarily goes to A- (lower right) instead goes to C+, while C- goes to A-. This is not a very good way to prevent oscillation, not because it does not work, but because the damping effect is very costly in point of diminished amplification. It is the same principle employed when a potentiometer is inserted across the A battery with grid return to the movable arm. The neutralizing condenser method is more efficient, as is the Scott-Taggart method of alternate tuned and untuned stages, employing RF choke coils in the untuned steps. Note that the diagram is simply an inversion of the usual C battery connections, positive instead of negative bias.

WHERE CAN I purchase an AC transformer, 30 henry choke coil and condenser for the Apco B battery eliminator?—Thos. Coakley, 354 Bergen Ave., Jersey City, N. J. Stanley and Patterson Electric Co., West and Hubert Streets, N. Y., N. Y.

WITH REFERENCE to the Reinartz Short-wave Receiver described in the May 16 issue of RADIO WORLD, will you kindly advise me where I may purchase the radio-frequency choke coil "C" mentioned therein?—R. G. Boatright, Box 512, Colburn, Va. The Zenith Radio Corporation, 332 S. Michigan

Ave., Chicago, Ill. This same article may also be purchased from your local dealer who handles transmitting apparatus.

COULD I use a C battery in my radio-frequency amplifier with success in the Anderson Super-dyne, as described in the Nov. 22 and 29 issues of RADIO WORLD?—L. Wm. Rush, Blauvelt, N. Y.

Yes, but the action which takes in the tube will be similar to that of the detector, that is, a charge of electrons will be built up through the battery, until a point of saturation is reached and it will discharge, thereby causing the tube to rectify. However, the C battery will save about half your B battery consumption for that tube. On account of the coils and the capacity the C battery will be effective enough, not to interfere with reception.

IS THERE any advantage gained by winding the coils in astatic fashion? (2) I have built the 3-circuit Tuner You Can Log and find that by taking out detector tube I get the same results as with the tube in the socket. What is the trouble?—E. J. Love, Box 128 South San Francisco, Cal.

(1) Yes, selectivity and volume are thereby improved. (2) You have the same trouble that a great many others have. Your detector does not regenerate, which can easily be cured, reverse tickler leads. Put a .001 mfd. fixed condenser across the tickler leads. Push prongs of tube socket up, put a new variable grid leak in, so that you obtain the exact amount of megohms that the grid of your tube requires to discharge across the fixed condenser. Add more plate voltage.

I HAVE built the Diamond of the Air, using the D21 Sodian detector tube and I find that regeneration is very hard to control; also that the tube is very noisy. I do not get DX on my speaker.—Miss Rose Spooner, 514 N. Potomoc St., Baltimore, Md.

Use less B battery voltage and be sure that your grid leak functions. The Sodian will "plop" very severely if the B voltage is too high. Disregard all advice as to which voltage is best and be guided only by your own experience. The easy spilling over merely proves that the tube oscillates readily, which it should, but external

means must be provided for holding this tendency in check. All else failing, remove a few turns from the tickler coil. If the tube is noisy, test your rheostat to see if it affords gradual variation in tube lighting. About 20 ohms is correct for this tube.

Ordinarily this tube is not critical on filament voltage, but occasionally resembles the UV200 and C300, which are critical and when "overfed" occasion "rushing" noises. Try reversing the detector grid return (making it to positive). If no improvement results, restore the connection and put the leak from grid to negative A, instead of to positive A.

I RECENTLY purchased a Music Master loud speaker and for about six months it worked fine. Recently someone slightly jarred it and it distorts.—H. J. Rosen, N. Y. C.

When you jarred it you must have bent the diaphragm. Send it back to the factory. The wires on the poles also may have lost their magnetism, which can be easily repaired by your local radio dealer, who will remagnetize the phone unit.

I HAD an argument with a friend who stated that by installing a lightning arrestor the total volume of the receiver decreases.—L. H. Barloms, Lake View, N. J.

The only time the arrestor will have any effect on the reception is when it either gets shorted internally or it has an internal leak, caused by the poor insulation being put on the covering of the arrestor. You were right on principle.

I WOULD like to know how to make my receiver set reach the high wavelength?—W. J. Romaine, 153 West 46th St., N. Y. C. See the May 16 issue of RADIO WORLD; also the article in this issue.

I HAVE a 5-tube Atwater-Kent set and I cannot get rid of WHN which is about six blocks away from me. This also prevents me from getting any distance.—J. Ward, 723 11th Ave., N. Y. C.

Turn your antenna at right angles to the radio station, also reduce the total length of your aerial so as to obtain sharper tuning. Put a variable condenser in series with the antenna, shunting the same with a 59-turn coil, wound on a 3" diameter tubing with No. 22 DCC wire.

WOULD YOU please give a hookup of the Radio Corporation of America Second Harmonic Super-Heterodyne?—J. Litvok, 407 New Jersey Ave., Brooklyn, N. Y.

The diagram was published in the September 6 issue. I would not advise you to build this set, as it is extremely difficult to do so, requiring factory facilities. The Super-Heterodyne is hard enough to get to work right, as is, and when you employ the second harmonic, reflexed, you get into steep water.

IS THE Superdyne efficient when transformer-coupling is employed instead of tuned radio frequency? (2) Is regeneration employed in the Superdyne?—W. H. W. Cassell, 108 London Street, Portsmouth, Va. (1) Not as efficient. (2) Yes.

WHY does the law require that the logarithmic decrement shall not exceed 0.2?—Frank J. Jolly, Jr., Station A, Ogdensburg, N. Y.

Any wave which has a higher decrement is an interfering, broad wave and therefore annoys listeners to other senders. Pure CW has no decrement.

WHAT three types of antennas are there and how are they beneficial or unbeneficial to the

Join RADIO WORLD'S University Club

and we will enter your name on our subscription and University lists by special number. Put this number on the outside of your envelope addressed to RADIO WORLD (not the enclosed return envelope) and also put it in your queries and the questions will be answered the same day as received.

And Get Free Question and Answer Service for the Coming 52 Weeks.

RADIO WORLD, 1493 Broadway, New York City:

Enclosed find \$6.00 for RADIO WORLD for one year (52 Nos.) and also consider this an application to join RADIO WORLD'S University Club, which gives me free information in your Radio University Department for the coming year, and a number indicating my membership.

Name

Street

City and State

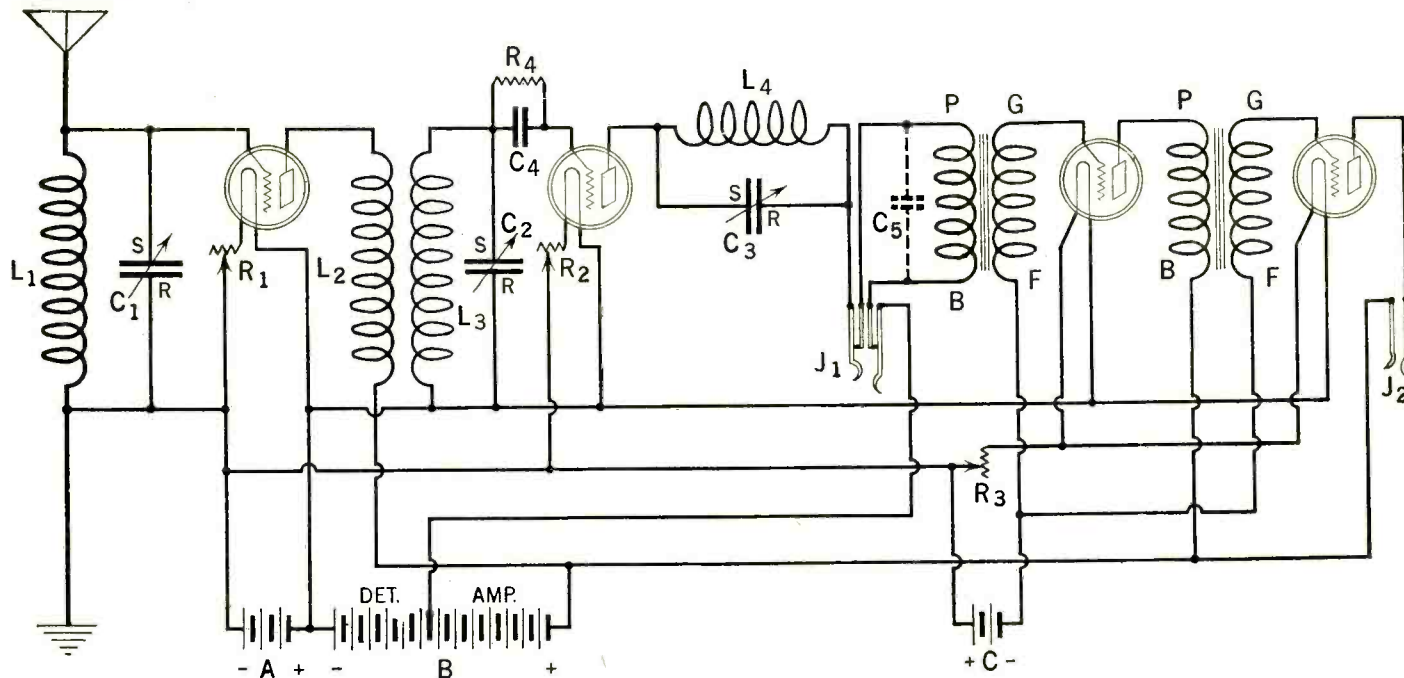

FIG. 153, the 3-circuit tuner you can log, preceded by a stage of impedance-coupled tuned RF. Honeycomb or duolateral coils may be used. L1 has 55 turns (a 75-turn coil, 20 turns removed). Try taking off 15 turns first then one at a time. L3 is 60-turn honeycomb, L4 is 65. The primary L2 is 10 turns of No. 24 SSC wire wound so as to fit inside of L3. C1, C2, C3 are .0005 mfd. R4 is a 2 meg, grid leak, C4 is .00025. C5 should be .001, placed preferably across the outside prongs of the jack J1, rather than as shown in diagram 1 although both ways work. R1 and R2 are rheostats for the particular tubes used, which may be any oscillators. R3 is about half the resistance of either R1 and R2, as it controls two tubes. The C battery should be 4½ volts for 90 on the plate. This set is selective and provides plenty of volume. Mount successive coils at right angles.

transmitter?—L. V. Beckson, Oakland, Cal.

Of the three types of antennas, the vertical is the best, since it is only one which radiates most of the electromagnetic energy, which is being transferred from the closed oscillatory circuit to the open oscillatory to antenna. This one is very inconvenient, as it takes up a great deal of room, and cannot easily be installed either aboard ship or on housetop, etc. We next have the flat top, which is divided into two classes, the inverted L, and the T type. The inverted L antenna, has a much longer wavelength, than the T type, which is of the same dimensions. The inverted L antenna is somewhat directional and radiates most of the energy in the direction or field which is opposite to the free end, while type T radiates energy with equal strength from both ends. Getting back to the vertical aerial this radiates, with equal signal strength in all directions. However, such an antenna is expensive to build, because to obtain the proper inductance and capacity we need a very high mast and a great many guy wires, also a large span of land. This however, is not true of the flat top antennas, as both may have low masts (6 or 7 wires being used and being very long will equal the capacity and inductance that you are desirous of obtaining).

I HAVE heard so much of tightening and loosening the coupling of receivers that I desire information as to just what this means.—N. O. O'Connell, Long Beach, Cal.

When you tighten the coupling (put the antenna detector coils closer together) you increase the broadness of the tuning of the set and make it respond to a larger number of wavelengths. This is very helpful to the commercial operator, who may be listening for an SOS, but to the BCL, it is a nuisance, and is what most are trying to get away from. With a tight coupled set you can receive louder signals, as the mutual inductance between the primary and secondary is increased thereby passing more energy to the secondary. When using loose coupling (antenna and detector farther apart) the signals are weaker, but the selectivity is made greater. The tight coupling introduces more apparent resistance. It is the relatively low resistance that affords selectivity.

I HAVE a Westinghouse single-tube double circuit, regenerative set and have received the following stations: WGAO, KFKX, WVT, WLS, etc. Do you think this is a good record? (2) The set has a wooden panel. Would the efficiency of the set be increased if I put a hard rubber panel on?—L. Gaylord, 2600-4-SN, St. Petersburg, Fla.

(1) The section that you are in is not very good for reception, yet you have fared very well. (2) It might, but your results justify you in leaving the panel as it is.

I DESIRE a diagram of a 4-tube circuit that can be logged using regeneration.—Amber Croft, Beloit, Wis.

See Fig. 153.

WOULD IT not be more efficient to introduce

FIXING YOUR ADJUSTABLE CRYSTAL

By Herbert E. Hayden

Illustrations by the Author

A FIXED crystal is nothing more than an adjustable one with the contact made permanent. If you want to make a fixed crystal out of your adjustable one, and avoid tedious experimenting for the most sensitive spot every time the catwhisker is jarred out of place, use the method portrayed in Figs. 1, 2 and 3. The result will be a product on a par with the usual fixed crystals. But you will have the satisfaction of knowing that you yourself picked out the most sensitive spot. Moreover, if after lapse of considerable time the sensitivity diminishes, you can scrape off the sealing wax, find a new sensitive spot and seal the catwhisker as previously.

regeneration in a 3-tube circuit with two stages of RF amplification, by a tickler connected to the plate of the detector tube and acting on the secondary winding of the first RF transformer? (2) Could this be done on the Roberts circuit?—Bernard Plata, 424-A East Ave., Los Angeles, Cal.

This is a successful way, when dealing with odd-numbered stages, but such a set is a bit unstable if the phase relationship of the tubes is ignored. (2) Yes.

I WANT to know how to wind my Neutrodyne coils in the low-loss fashion, viz.: the primary wound over the secondary by means of holding bridges.—R. Hoffman, 139 McLain St., Dayton, O. Wind ten turns of No. 20 DCC on bridges for primary. The secondary has 50 turns of No. 22 DCC wire. All windings are in the same direction. The bridges ¼" in length. The diameter is 3", the condensers .0005. Use 60 turns for secondary if .00035 is to be used, 15 turns on primary.

A 3-TUBE REFLEXED NEUTRODYNE, by Percy Warren. Send 15c for May 16 issue, RADIO WORLD.

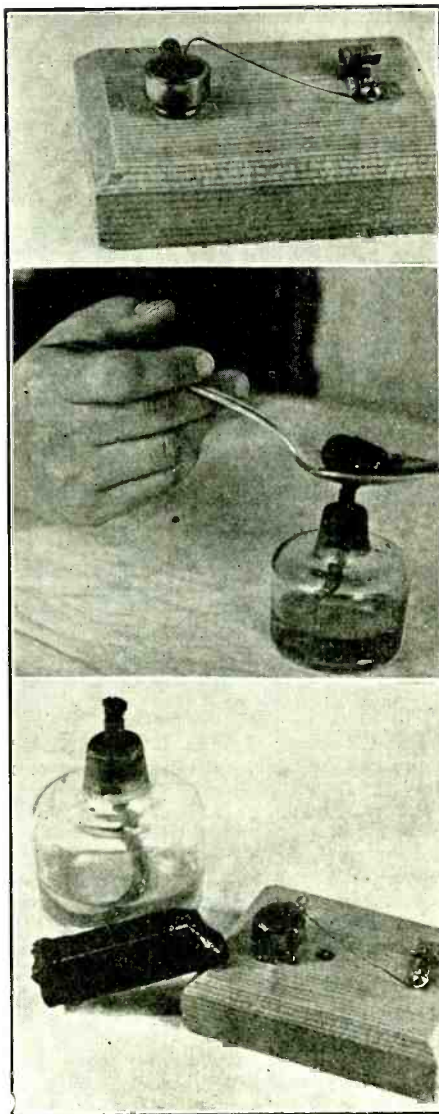

A 3-TUBE REFLEXED NEUTRODYNE, by Percy Warren. Send 15c for May 16 issue, FIGS. 1, 2 and 3, top to bottom, showing crystal "fixing."

A FULL AND AUTHORITATIVE LIST OF AMERICAN BROADCASTING STATIONS, CORRECTED UP TO DAY OF GOING TO PRESS, WILL APPEAR IN VACATION NUMBER OF RADIO WORLD, DATED JUNE 6, OUT NEXT WEEK.

Girls Simply Must Ignore Sign But It's in a Good Cause



ON THE door is a sign reading "quiet," but these girls don't believe in signs. They are giving three cheers for the successful broadcasting from WHT, Chicago, of a full day of religious program. The service lasts 10 hours and is the longest service held by any station in the world. (Underwood & Underwood)

Sets Barred in German Jails; Prisoners Protest, As Bars Made Excellent Antennas

BERLIN.
PRISONERS in German jails are not entitled to have radio sets in their Head—Sets Barred in German Jails cells, the authorities have decided. Plea for a radio was made by two of the Kutisker brothers, who were arrested with

their father early this year in connection with the German finance scandals. They wanted to use the bars of their cells for antennas. Their lawyers have appealed and are determined to carry the issue to the highest courts.

The lawyers demand their fees first.

More Accurate Wavemeter Designed by U. S. Bureau

WASHINGTON.
THE Bureau of Standards Radio Laboratory has devised a portable wavemeter which can be used in the place of the thermogalvanometer. A resonance indicator as used on most portable wavemeters commonly consists of a thermogalvanometer connected in series in the tuned circuit of the wavemeter. The use of this instrument reduces the precision of setting the wavemeter condenser, because it adds to the resistance of the wavemeter and because it gives comparative small resonance deflections at low settings of the condenser.

The new portable wavemeter gives an approximately uniform resonance deflection over the frequency range of the wavemeter, does not appreciably increase its resistance and is more sensitive than the thermogalvanometer. The method

employs a sensitive milliammeter and a crystal detector connected in such a manner that a combination of capacitive and inductive coupling is obtained with respect to the wavemeter circuit.

The operation of a wavemeter equipped with this device is not quite as simple as the operation of a wavemeter equipped with the thermogalvanometer because it requires an adjustment of the crystal detector. However, if the detector is of good mechanical design and is provided with a crystal of uniform sensitivity this is not a great drawback. Experimental data are given to show that this method of resonance indication permits precise settings of the wavemeter condenser. The resonance indicator may be added to most portable wavemeters and results in greater precision in their use.

A PUSH-PULL AF AMPLIFIER
with diagrams; in RADIO WORLD, dated May 9, 15c. per copy, or start your subscription with that number. RADIO WORLD, 1493 Broadway, New York City.

GETTING BETTER QUALITY FROM AUDIO,
by Brewster Lee. Last AF stage connected to two tubes in parallel. Send 15c for May 16 issue to RADIO WORLD, 1493 Broadway, New York City.

Canadian Ships to Send on Higher Waves, Thus Cutting Interference

WASHINGTON.
AS a result of the conference held at Detroit between radio officials of the American and Canadian Governments, agreement was reached that in the future Canadian ship and land stations will transmit on 715 and 850 meters instead of on 600.

It is expected that this transfer will greatly reduce interference to fans who have been complaining of picking up a lot of Canadian harmonics in the broadcast band.

New Broadcasters

WASHINGTON.
FOUR new class A stations and one class B station were licensed by the Department of Commerce. The new stations:

CLASS A			
Call	Station	Meters	Watts
WGBW	Hub Radio Shop & Valley Theatre, 100 Illinois St., Spring Valley, Ill.	256	10
WIBK	University of the City of Toledo, Cor. 11th & Ill. Sts., Toledo, O.	205.4	100
WIBI	Frederick B. Zittel, Jr., 369 Amity St., Flushing, N. Y.	218.8	5
WIBJ	C. L. Carrell, Chicago, Ill. (Portable)	215.7	50
CLASS B			
Call	Station	Meters	Watts
WHT	Radiophone Broadcasting Corp., Waukegan Rd., Deerfield, Ill.	238	1500

News Sent Regularly to Ships World Over by Two Power Stations

THE Radio Corporation of America inaugurated an ocean-wide service completely covering the Atlantic and Pacific oceans. Two high-powered stations, one at New Brunswick, N. J., and one in San Francisco, will furnish daily news reports by relay to all parts of the world. The first tests were conducted at 3 a. m., when the station at New Brunswick sent out flashes picked up on the Pacific coast and in Honolulu, so that the message was literally flashed around the world.

GREATER A. & P. RADIO ACCUSED OF NEUTRODYNE PIRATING

MAGISTRATE SIMPSON, sitting in the Commercial Frauds Court, New York City, directed that a complaint be made against the Greater Atlantic and Pacific Radio Company of 233 West Thirty-fourth Street, charging that firm with violation of the law prohibiting the illegal use of trademarks.

The radio company was accused by the American Fair Trade League of advertising without right that it had for sale "Neutrodyne" radio sets, and selling one of these sets to Frank M. Douglas, an agent of the league.

ONE TUBE MORE FOR QUALITY; The 3-Tube Neutrodyne Using the Reflex Plan; The Short-Wave Receiver Reinartz Will Use in Arctic—all these appeared in RADIO WORLD, dated May 16. 15c. per copy, or start your subscription with this number. RADIO WORLD, 1493 Broadway, New York City.

SIX SPEAKER CIRCUITS THAT CAPTIVATED DISCERNING FANS

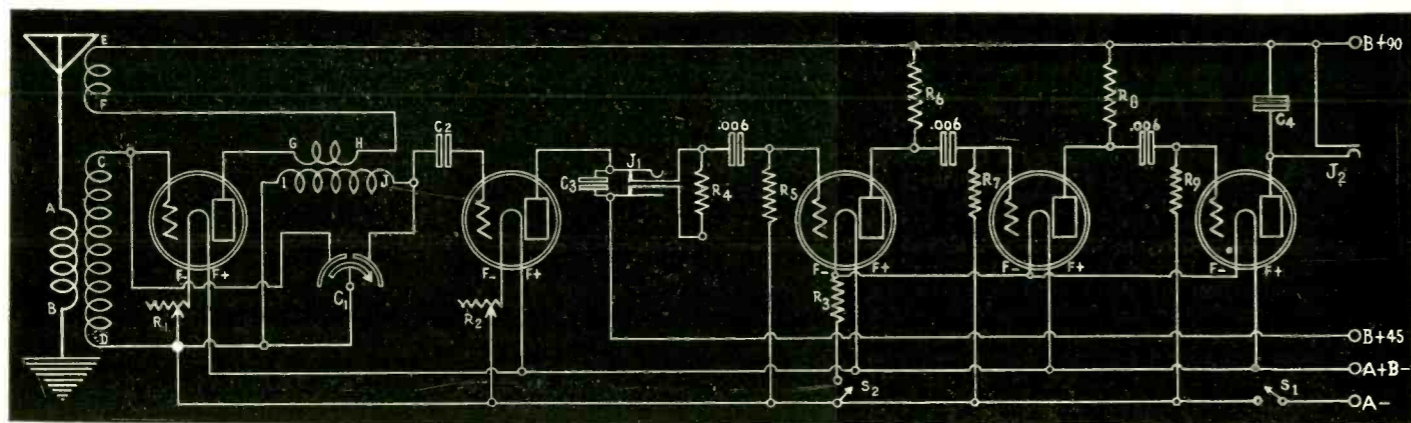

FIG. 1—Where regeneration is used, one RF stage is about all that can be used with dependable success. The above circuit uses a double condenser, having a single rotor and two separate stators, each section .0005 mfd. The regeneration is in the RF stage. The commercial types of 3-circuit coil works nicely here. The RFT should have about the same inductance as the primary and secondary of the 3-circuit coil, respectively. The set is great for DX and as resistance-coupled AF is used, the volume is good and the quality superb. The coils if home-made may be of No. 24 DSC wire, 10-turn primaries, 43-turn secondaries, on 3/4" diameter tubings. The tickler would have 30 turns of No. 26 SSC wire on a 2 3/4" diameter. See Fig. 2 for audio resistor values.

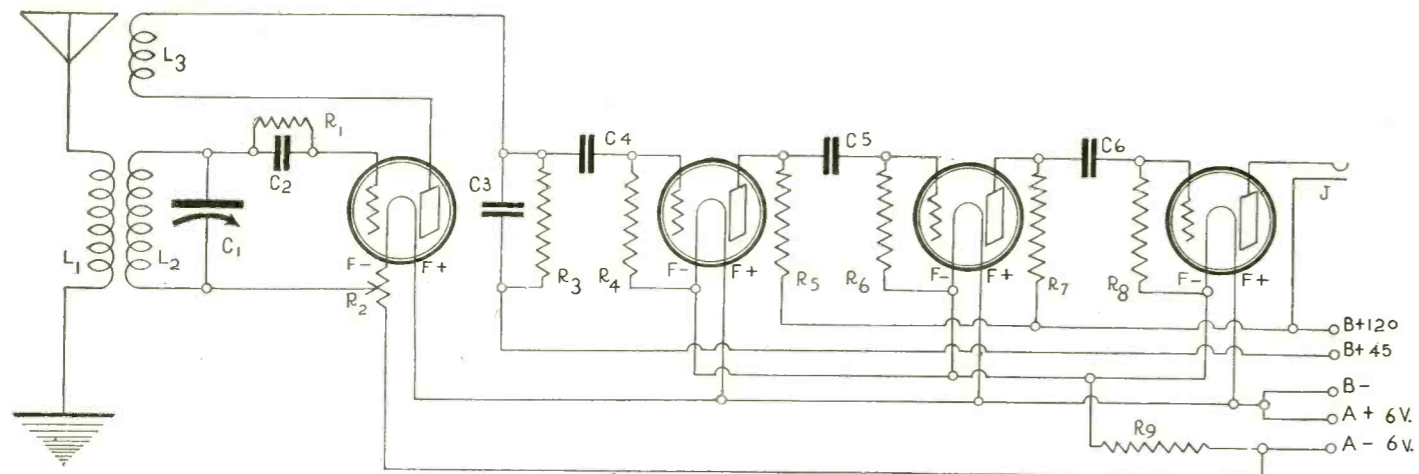

FIG. 2, the 3-circuit tuner, with rotary tickler coil, resistance-coupled audio being used because of the splendid quality it affords. This is fundamentally the Fig. 1 circuit with the RF stage omitted. The same kind of coil may be used for L1L2L3 here as in Fig. 1. C1 is .0005. Use UV201A, C301A or DV2 for the audio stages. These require a 6-volt storage battery. R3, R5 and R7 are 100,000 ohms (1/10 meg.), while R4 is 1,000,000 ohms (1 meg.); R6, 500,000 ohms (1/2 meg.); R8, 250,000 ohms (1/4 meg.). R9 is a ballast resistance (Daven) for controlling the filaments of three tubes at once. C4, C5 and C6 are .006 mfd. each. C3 is important here. It is .002. Use a higher plate voltage than usual on the detector. On the audio plates 90 to 135 will do the work, 90 being all right.

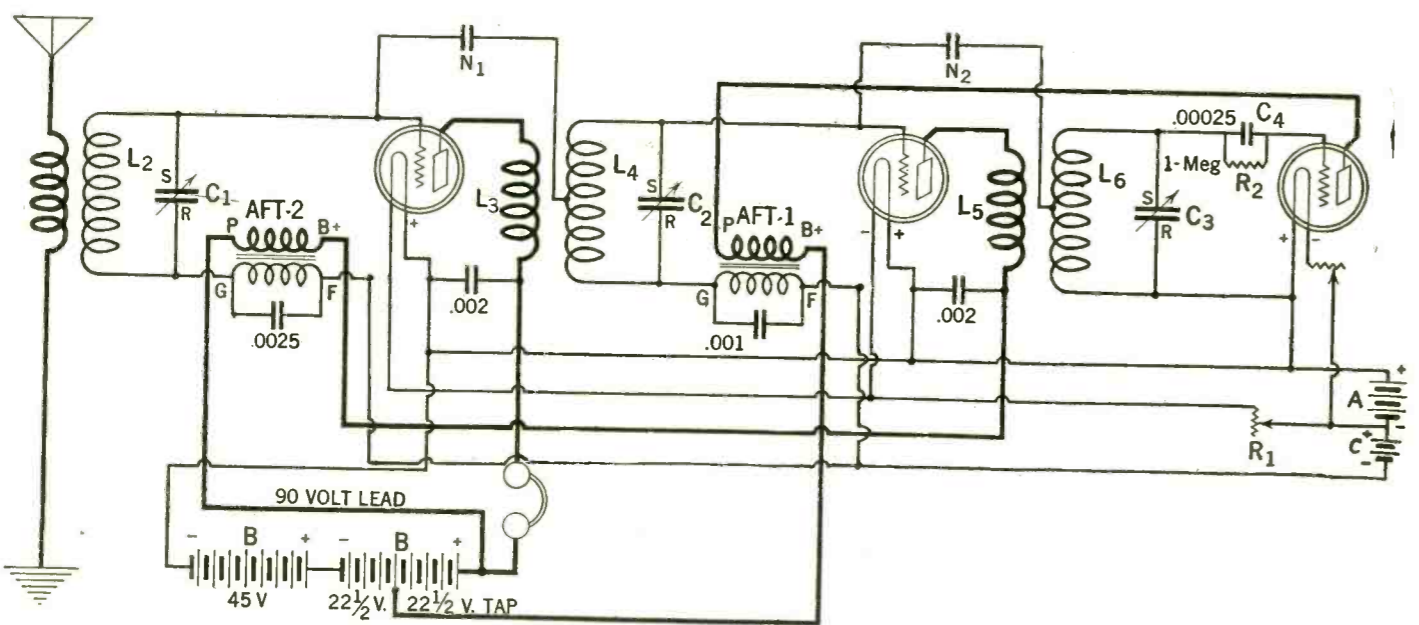

FIG. 6—Only three tubes are used here, but audio amplification is obtained in great volume. This is the 3-tube reflexed Neutrodyne, embodying the two tuned RF stages into which are reflexed the audio stages, but in reverse fashion, that is, first AF in second RF and second AF in first RF. This is a hard circuit for the novice and indeed may give the tried experimenter some anxious and interesting moments. But it is a thoroughly practical set and has given wonderful results to the favored ones. The Neutrodyne does not radiate and it is simpler to tune, because of quietness attending dial operation, than any of the other circuits on this page. As the set is recommended only to experienced fans, no detailed information as to the Neutroformers, etc., is given here.

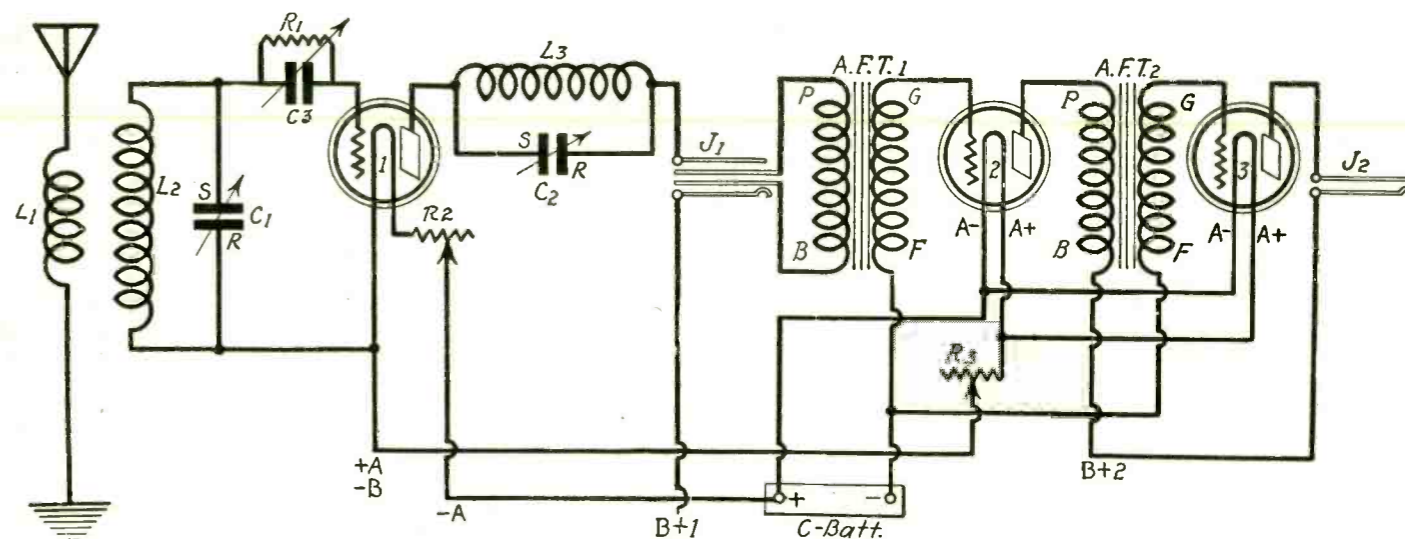

FIG. 4, Bernard's famous 3-Circuit Tuner You Can Log. This is a very simple circuit to construct and indeed an efficient and attractive one. L1L2 may be honeycomb coils, likewise L3. If C1 and C2 are .0005 mfd., then L2 is a 65-turn coil, L1 a 10-turn winding placed over or inside it, the ten turns removed from the 75-turn HC being available. C2 should be 75 full turns, but turns should be taken off, one at a time, until the two condensers tune in step. This they should do for most of the dial readings, but can not be expected to tune instep all the way through. But from one end of the dials to the other the set can be logged, every station coming in at the same readings time and time again. A C battery is inserted in the audio stages to conserve B battery consumption and increase tube efficiency (if the tubes are weakening with age).

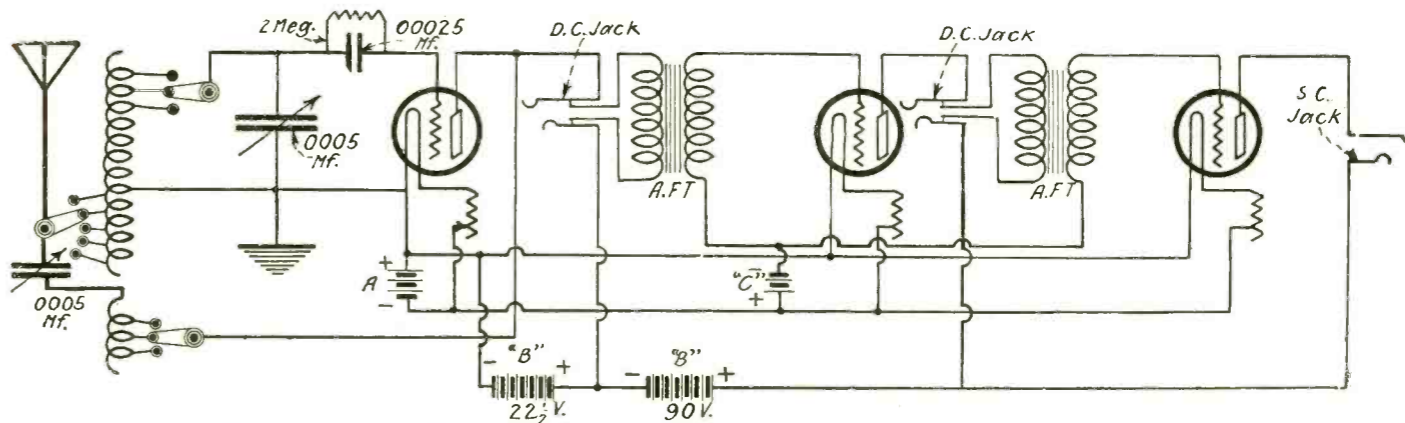

FIG. 5—One of the most satisfactory of radio receivers is the Reinartz set as designed by John L. Reinartz, originator of the new short-wave receiver. The most important part of the set is the special spider web form. The coil is wound with No. 22 DCC wire, in a spider web design on nine spokes, around a 2 1/2" center, the complete coil being 5 1/2" outside diameter. Starting from the center, wind 15 turns and take a tap off, continue winding 15 more turns and take another tap off, continue winding 15 more turns and take the final tap off. Cut the wire off and begin to wind the other coil (wrap a piece of wire on spoke for holding) which consists of 40 turns tapped in the following fashion (all winding in the same direction): A tap is brought out after the second turn, continue winding 2 more turns, bring another tap out, continue winding and tap every two turns until the 8th turn is reached; take a tap off the coil at the ninth turn and at the tenth turn. Continue winding 15 more turns and take off another tap, the wiring being continued until 5 more turns have been added and continue the winding for ten more turns, taking off the last tap which is at the 40th turn. You now have eleven taps on the outside coil and four taps on the inner coil. If the audio amplifiers do not work successfully, insert a 75-turn honeycomb coil in the plate circuit of the detector tube.

How the Six Circuits Compare

ON this page are published six circuits. One of them (Fig. 3) uses two tubes and is a reflex, operating a speaker on local stations only. Three of them are 3-tube sets—Fig. 4, the 3-Circuit Tuner You Can Log; Fig. 5, the Reinartz and Fig. 6, the reflexed Neutrodyne. Fig. 6 embodies the conventional stages and includes the inverse duplex method. It is no easy set to build. Fig. 1 is a stage of regenerative RF ahead of a non-regenerative detector, and Fig. 2 is the 3-circuit tuner (not loggable as to tickler), with rotary tickler instead of condenser-tuned plate. Both of these are followed by resistance-coupled AF. For the novice Fig. 4 will prove most attractive, since it is the easiest to build and the most economical for local and DX speaker operation. The extra tube required by resistance AF is well worth while to those who enjoy quality reception. Except in the resistance-coupled audio stages, any oscillating tubes may be used. But the larger tubes

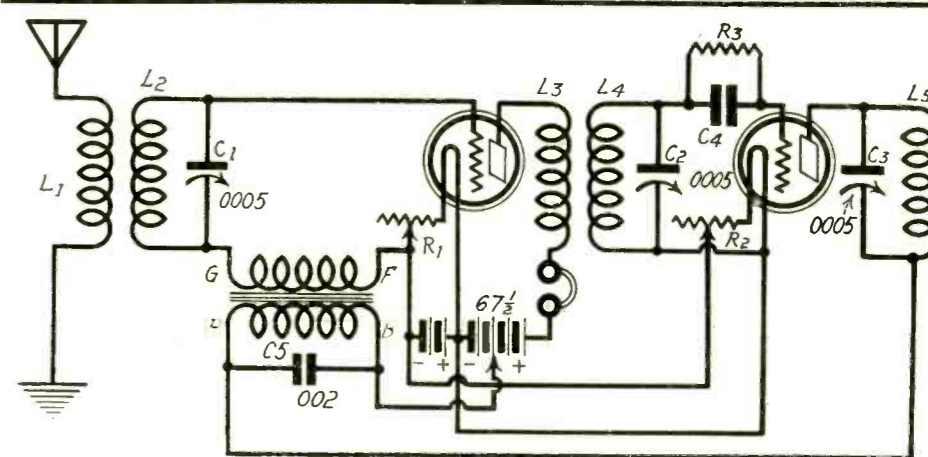

FIG. 3—While this circuit will work a speaker, it will do so only on locals, say stations less than eight miles away. But it is a wonderful carphone reflex, being able to get distance consistently. It comprises a stage of RF, detector and a stage of reflexed AF. Astatic windings are preferred, but the coil directions given in Fig. 1 may be applied, L5 having two more turns than the secondary (L2) of the RFT. The tuned plate method is used to obtain regeneration.

give more volume and hence come in handier in the resistance sets, because the total volume from the resistance amplifier, while it may occasionally be as great as from the two-stage transformer-coupled type, is not greater.

THE KEY TO THE AIR

KEY

Abbreviations: E. S. T., Eastern Standard Time; C. S. T., Central Standard Time; M. S. T., Mountain Standard Time; P. S. T., Pacific Standard Time; D. S., Daylight Saving Time.

How to tune in a desired distant station at just the right time—Choose your station from the list published herewith. See what time division the station is under (E. S. T., C. S. T., etc.); then consult the table below. Add to or subtract, as directed from the time as given on the PROGRAM. The result will be the same BY YOUR CLOCK that you should tune in, unless daylight saving time intervenes, as explained below.—The table:

Table with columns: If you are in, And want a station in, Subtract, Add. Rows list various time zones and their corresponding adjustments.

If you are under Daylight Saving Time, and the station you want is under that time, too, or if both are under Standard Time, the above table will hold.

If you are under Daylight Saving Time, and the station operates under Standard Time, add one hour to the table result.

If the station uses Daylight Saving Time, and you are under Standard Time, subtract one hour from the table result.

Friday

WAAM, Newark, N. J., 263 (E. S. T., D. S.)—11 A. M. to 12. WAHG, Richmond Hill, N. Y., 316 (E. S. T., D. S.)—12 to 1:05 P. M.; 8 to 12 P. M. WAMD, Minneapolis, Minn., 243.8 (C. S. T.)—12 to 1 P. M.; 10 to 12. WBBM, Chicago, Ill., 226 (C. S. T.)—8 to 10 P. M. WBBR, New York City, 272.6 (E. S. T., D. S.)—8 P. M. to 10. WBZ, Springfield, Mass., 333.1 (E. S. T., D. S.)—6 P. M. to 11. WCCO, St. Paul and Minneapolis, Minn., 416.4 (C. S. T.)—9:30 A. M. to 12 M.; 1:30 to 4; 5:30 to 10. WCAE, Pittsburgh, Pa., 461.3 (E. S. T., D. S.)—12:30 to 1:30 P. M.; 4:30 to 5:30; 6:30 to 11. WDAF, Kansas City, Kansas, 365.6 (C. S. T.)—3:30 to 7 P. M.; 8 to 10; 11:45 to 1 A. M. WEAJ, New York City, 492 (E. S. T., D. S.)—6:45 A. M. to 7:45; 11 to 12; 4 P. M. to 5; 6 to 12. WEAR, Cleveland, O., 390 (E. S. T.)—11:30 A. M. to 12:10 P. M.; 3:30 to 4:10; 8 to 11. WEAQ, Ohio State University, 293.9 (E. S. T.)—8 P. M. to 10. WEEL, Boston, Mass., 476 (E. S. T., D. S.)—6:45 A. M. to 7:45; 2 P. M. to 3:15; 5:30 to 10. WEMC, Berrien Springs, Mich., 286 (C. S. T.)—9 P. M. to 11. WFAA, Dallas, Texas, 475.9 (C. S. T.)—10:30 A. M. to 11:30; 12:30 P. M. to 1; 2:30 to 6; 6:45 to 7; 8:30 to 9:30. WGBS, New York City, 316 (E. S. T., D. S.)—10 A. M. to 11; 1:30 P. M. to 4; 6 to 11. WGR, Buffalo, N. Y., 319 (E. S. T., D. S.)—12 M. to 12:45 P. M.; 7:30 to 11. WGST, Atlanta, Ga., 270 (C. S. T.)—7 P. M. to 8. WGY, Schenectady, N. Y., 379.5 (E. S. T.)—1 P. M. to 2; 5:30 to 10:30. WHAD, Milwaukee, Wis., 275 (C. S. T.)—11 A. M. to 11:30; 6 P. M. to 8. WHAS, Louisville, Ky., 399.8 (C. S. T.)—4 P. M. to 5; 7:30 to 9. WHN, New York City, 360 (E. S. T., D. S.)—12:30 P. M. to 1; 2:15 to 5; 7 to 11; 12 to 12:30 P. M. WHO, Des Moines, Iowa, 526 (C. S. T.)—7:30 P. M. to 9; 11 to 12; 12:30 to 1:30; 4:30 to 5:30; 6:30 to 9:30. WIP, Philadelphia, Pa., 508.2 (E. S. T., D. S.)—7 A. M. to 8; 1 P. M. to 2; 3 to 4:50; 6 to 8. WJY, New York City, 405 (E. S. T., D. S.)—7:30 P. M. to 11:30. WJZ, New York City, 455 (E. S. T., D. S.)—10 A. M. to 11; 1 P. M. to 2; 4 to 6; 7 to 10:30. WLIT, Philadelphia, Pa., 395 (E. S. T.)—12:02 P. M. to 12:30; 2 to 3; 4:30 to 6; 7:30 to 1 A. M. WLW, Cincinnati, O., 422.3 (E. S. T.)—10:45 A. M. to 12:15; 1:30 P. M. to 2:30. WMCB, New York City, 341 (E. S. T., D. S.)—3 P. M. to 5; 6:30 to 7:30; 8:15 to 8:20; 9 to 10:15; 11 to 11:30. WNYC, New York City, 526 (E. S. T., D. S.)—3:45 P. M. to 4:45; 6:20 to 11. WOAW, Omaha, Neb., 528 (C. S. T.)—12:30 P. M. to 1; 5:45 to 7:10; 9 to 11. WOC, Davenport, Iowa, 484 (C. S. T.)—12:57 P. M. to 2; 3 to 3:30; 5:45 to 12. WOR, Newark, N. J., 405 (E. S. T., D. S.)—6:45 A. M. to 7:45; 2:30 P. M. to 4; 6:15 to 7. WPAK, Fargo, N. D., 283 (C. S. T.)—7:30 P. M. to 9. WPG, Atlantic City, N. J., 299.8 (E. S. T., D. S.)—7 P. M. to 8:30; 10 to 12. WQJ, Chicago, Ill., 448 (C. S. T.)—11 A. M. to 12 M.; 3 P. M. to 4; 7 to 8; 10 to 2 A. M. WRC, Washington, D. C., 469 (E. S. T.)—4:30 to 5:30 P. M.; 6:45 to 12.

Saturday

WAAM, Newark, N. J., 263 (E. S. T.)—7 P. M. to 11. WAHG, Richmond Hill, N. Y., 316 (E. S. T., D. S.)—12 M. to 2 A. M. WAMD, Minneapolis, Minn., 243.8 (C. S. T.)—12 M. to 1 P. M.; 10 to 12. WBBM, Chicago, Ill., 226 (C. S. T.)—8 P. M. to 1 A. M. WBBR, New York City, 272.6 (E. S. T., D. S.)—8 P. M. to 9. WBZ, Springfield, Mass., 333.1 (E. S. T., D. S.)—11 A. M. to 12:30 P. M.; 7 to 9. WCAE, Pittsburgh, Pa., 461.3 (E. S. T., D. S.)—10:45 A. M. to 12 M.; 3 P. M. to 4; 6:30 to 7:30. WCBM, Zion, Ill., 344.6 (C. S. T.)—8 P. M. to 10. WCCO, St. Paul and Minneapolis, Minn., 416.4 (C. S. T.)—9:30 A. M. to 12:30 P. M.; 2:30 to 5; 6 to 10. WEAJ, New York City, 492 (E. S. T., D. S.)—6:45 A. M. to 7:45; 4 P. M. to 5; 6 to 12. WEEL, Boston, Mass., 476 (E. S. T., D. S.)—6:45 A. M. to 7 A. M. WEAR, Cleveland, O., 390 (E. S. T.)—11:30 A. M. to 12:10 P. M.; 3:30 to 4:10; 7 to 8. WEMC, Berrien Springs, Mich., 286 (C. S. T.)—11 A. M. to 12:30 P. M.; 8:15 to 11. WFAA, Dallas, Texas, 475.9 (C. S. T.)—12:30 P. M. to 1; 6 to 7; 8:30 to 9:30; 11 to 12:30 A. M. WGBS, New York City, 316 (E. S. T., D. S.)—10 A. M. to 11; 1:30 P. M. to 3; 6 to 12. WGR, Buffalo, N. Y., 319 (E. S. T., D. S.)—12 M. to 12:45 P. M.; 2:30 to 4:30; 7:30 to 8. WGY, Schenectady, N. Y., 379.5 (E. S. T.)—7:30 P. M. to 10. WHAD, Milwaukee, Wis., 275 (C. S. T.)—11 A. M. to 11:30; 6 P. M. to 8. WHAS, Louisville, Ky., 399.8 (C. S. T.)—4 P. M. to 5; 7:30 to 9. WHN, New York City, 360 (E. S. T., D. S.)—2:15 P. M. to 5; 7:30 to 10. WHO, Des Moines, Iowa, 526 (C. S. T.)—11 A. M. to 12:30 P. M.; 4 to 5:30; 7:30 to 8:30. WIP, Philadelphia, Pa., 508.2 (E. S. T., D. S.)—7 A. M. to 8; 10:20 to 11; 1 P. M. to 2; 3 to 4; 6 to 11:30. WJY, New York City, 405 (E. S. T., D. S.)—2:30 P. M. to 5; 8 to 10:30. WJZ, New York City, 455 (E. S. T., D. S.)—9 A. M. to 12:30 P. M.; 2:30 to 4; 7 to 10. WKRC, Cincinnati, O., 326 (E. S. T.)—10 to 12 M. WLW, Cincinnati, O., 422.3 (E. S. T.)—9:30 A. M. to 12:30 P. M.; 7:30 to 10. WMAK, Lockport, N. Y., 265.5 (E. S. T.)—10:25 A. M. to 12:30 P. M. WMC, Memphis, Tenn., 499.7 (E. S. T.)—7:30 P. M. to 10. WMCB, New York City, 341 (E. S. T., D. S.)—3 P. M. to 3:15; 3:30 to 5; 8 to 8:15; 8:30 to 8:45; 11 P. M. to 1 A. M. WNYC, New York City, 526 (E. S. T., D. S.)—1 P. M. to 3; 7 to 11. WOAW, Omaha, Neb., 528 (C. S. T.)—9 A. M. to 11; 2:15 P. M. to 4; 9 to 11. WOC, Davenport, Iowa, 484 (C. S. T.)—12:57 P. M. to 2; 5:45 to 7:10; 9 to 12. WOO, Philadelphia, Pa., 508.2 (E. S. T., D. S.)—11 A. M. to 1 P. M.; 4:40 to 5; 10:55 to 11:02. WOR, Newark, N. J., 405 (E. S. T., D. S.)—6:45 A. M. to 7:45; 2:30 P. M. to 4; 6:15 to 7:30; 8 to 11. WPG, Atlantic City, N. J., 299.8 (C. S. T.)—7 P. M. to 12. WQJ, Chicago, Ill., 448 (C. S. T.)—11 A. M. to 12 M.; 3 P. M. to 4; 7 to 8; 10 to 3 A. M. WRC, Washington, D. C., 469 (E. S. T.)—4:30 to 5:30 P. M.; 6:45 to 12.

Sunday

WBBM, Chicago, Ill., 226 (C. S. T.)—4 P. M. to 6; 8 to 10. WBBR, New York City, 272.6 (E. S. T., D. S.)—10 A. M. to 12 M., 9 P. M. to 11. WCCO, St. Paul and Minneapolis, Minn., 416.4 (C. S. T.)—11 A. M. to 12:30 P. M.; 4:10 to 5:10; 7:20 to 10. WDAF, Kansas City, Kansas, 365.6 (C. S. T.)—4 P. M. to 5:30. WEAJ, New York City, 492 (E. S. T., D. S.)—3 P. M. to 5; 7:20 to 10:15. WEAR, Cleveland, O., 390 (E. S. T.)—3:30 P. M. to 5; 7 to 8; 9 to 10. WGR, Buffalo, N. Y., 319 (E. S. T., D. S.)—3:30 P. M. to 4; 7:15 to 8. WGBS, New York City, 316 (E. S. T., D. S.)—3:30 P. M. to 4:30; 9:30 to 10:30. WGY, Schenectady, N. Y., 379.5 (E. S. T.)—9:30 A. M. to 12:30 P. M.; 2:35 to 3:45; 6:30 to 10:30. WHAD, Milwaukee, Wis., 275 (C. S. T.)—2 P. M. to 3. WHN, New York City, 360 (E. S. T., D. S.)—1 P. M. to 1:30; 3 to 6; 10 to 12. WIP, Philadelphia, Pa., 508.2 (E. S. T., D. S.)—10:45 A. M. to 12:30 P. M.; 3:30 to 4:30. WKRC, Cincinnati, O., 326 (E. S. T.)—6:45 P. M. to 11. WNYC, New York City, 526 (E. S. T., D. S.)—9 P. M. to 11. WPG, Atlantic City, N. J., 299.8 (C. S. T., D. S.)—3:15 P. M. to 5; 9 to 11. WQJ, Chicago, Ill., 448 (C. S. T.)—10:30 A. M. to 12:30 P. M.; 3 P. M. to 4; 8 to 10. KFNF, Shenandoah, Iowa, 266 (C. S. T.)—10:45 A. M. to 12:30 P. M.; 2:30 to 4:30; 6:30 to 10. KOA, Denver, Colo., 322.4 (M. S. T.)—10:55 A. M. to 12 M.; 4 P. M. to 5:30 P. M.; 7:45 P. M. to 10 P. M. KGW, Portland, Oregon, 491.5 (P. S. T.)—10:30 A. M. to 12:30 P. M.; 6 to 9. KHJ, Los Angeles, Cal., 405.2 (E. S. T., D. S.)—10 A. M. to 12:30 P. M.; 6 to 9. KTHS, Hot Springs, Ark., 374.8 (C. S. T.)—11 A. M. to 12:30 P. M.; 2:30 to 3:40; 8:40 to 11.

Monday

WAAM, Newark, N. J., 263 (E. S. T., D. S.)—11 A. M. to 12 M.; 7 P. M. to 11. WAHG, Richmond Hill, N. Y., 316 (E. S. T., D. S.)—12 M. to 1:05 P. M.; 8 to 2 A. M. WAMD, Minneapolis, Minn., 243.8 (C. S. T.)—10 P. M. to 12. WBBM, Chicago, Ill., 226 (C. S. T.)—6 P. M. to 7. WBBR, New York City, 272.6 (E. S. T., D. S.)—8 P. M. to 9. WBZ, Springfield, Mass., 333.1 (E. S. T., D. S.)—6 P. M. to 11:30. WCAE, Pittsburgh, Pa., 461.3 (E. S. T., D. S.)—12:30 P. M. to 1:30; 4:30 to 5:30; 6:30 to 12. WCBM, Zion, Ill., 344.6 (C. S. T.)—8 P. M. to 10. WCCO, St. Paul and Minneapolis, Minn., 416.4 (C. S. T.)—9:30 A. M. to 12 M.; 1:30 P. M. to 6:15; 8 to 10. WDAF, Kansas City, Kansas, 365.6 (C. S. T.)—3:30 P. M. to 7; 8 to 10; 11:45 to 1 A. M. WEAJ, New York City, 492 (E. S. T., D. S.)—6:45 A. M. to 7:45; 4 P. M. to 5; 6 to 11:30. WEAR, Cleveland, O., 390 (E. S. T.)—11:30 A. M. to 12:10 P. M.; 3:30 to 4:10; 7 to 8. WEEL, Boston, Mass., 476 (E. S. T., D. S.)—6:45 A. M. to 8; 3 P. M. to 4; 5:30 to 10. WEMC, Berrien Springs, Mich., 286 (C. S. T.)—8:15 P. M. to 11. WFAA, Dallas, Texas, 475.9 (C. S. T.)—10:30 A. M. to 11:30; 12:30 P. M. to 1; 2:30 to 6; 6:45 to 7; 8:30 to 9:30. WGBS, New York City, 316 (E. S. T., D. S.)—10 A. M. to 11; 1:30 P. M. to 3; 6 to 7:30. WGR, Buffalo, N. Y., 319 (E. S. T., D. S.)—12 M. to 12:30 P. M.; 2:30 to 4:30; 7:30 to 11. WGST, Atlanta, Ga., 270 (C. S. T.)—9 P. M. to 10. WGY, Schenectady, N. Y., 379.5 (E. S. T.)—1 P. M. to 2; 5:30 to 8:30.

SQUIER LOSES AGAIN OVER THE "WIRED" PATENT

ANY patent developed by a Government employe through funds appropriated by Congress belongs to the public, the United States Circuit Court of Appeals ruled in New York City, in denying the appeal of Major-Gen. George O. Squier, former chief signal officer of the United States Army, now retired, in his "wired wireless" suit. The higher tribunal made its decision unanimous and upheld Federal Judge Knox, who had ruled against Squier in the District Court.

Millions of dollars were involved in the decision handed down. The suit involved as a defendant the American Telephone & Telegraph Company, The Westinghouse Electric & Manufacturing Company, the Radio Corporation of America, the General Electric and the Western Electric Company were also interested because of their activities in the development of "wired wireless," or the multiple telephone device.

Through the device, several messages can be transmitted over one wire, instead of one message at a time.

The decision affects, it is said, hundreds of patents now in the Patent Office—the sole work of men attached to the army, navy and marine corps. It also involves other governmental departments where employees have worked out devices which they have patented.

Circuit Judges Hough, Rogers and Manton heard the arguments on appeal. Major-Gen. Squier, as a major during 1909 and 1911, was assigned to do research work in wireless telegraphy for which there had been made available an appropriation by Congress amounting to \$30,000, the decision stated. When the officer had accomplished "wired wireless," he had it patented under the act of 1883, which provided that "it would be free to the public."

Commenting on this phase of the evidence the decision stated that "the plaintiff's own acts and his own words prevented him from recovering." Judge Hough expressed the opinion that Major-Gen. Squier, after proclaiming an intent to give the invention to the public, approved statements to the public press regarding his achievement and the benefits the public would derive from the same.

"Of course, the very existence of the suit shows the fit of public spirit has passed," said Judge Hough. "We are satisfied that the plaintiff wished to be generous in 1911. That he should regret that generous emotion is immaterial."

Major-Gen. Squier asked for an accounting of the profits which the A. T. & T. Co. had made since it had been using "wired wireless," and also prayed for an injunction against infringement upon his patent in the original suit, which he lost. He contended that the Government had a perfect right to utilize his patent, but that private use by any corporation or independent business concern was an infringement upon his rights.

COMPLETE LIST OF STATIONS

Brought up to date and published in RADIO WORLD dated May 2. All American, Canadian, Mexican and Cuban stations in this issue. 15c copy, or start your subscription with any number. RADIO WORLD, 1493 Broadway, New York City.

Radio Alarm Invented to Aid Police Catch Criminals



THE NEW POLICE RADIO ALARM—To left and right of the center plug are the signal lights. These are actuated from Police Headquarters. The light may be flashed at a single station, at several stations or at all stations at once. It means: "Listen in! An important police warning will be broadcast!" The device was demonstrated at the Police Conference. (Fotograms.)

THE International Police Conference saw a selective radio signaling system demonstrated in New York City as worked out by the Western Electric Company for Police Headquarters, using Station WNYC. The device can light a signal at any police station or police booth in the city, light the signals in all of them at the same time or light the signals in selected precincts.

This signal can be used to notify every precinct and booth in town simultaneously that something demanding general police attention is about to be broadcast by WNYC, so they may listen in. It may be used to

throw a radio cordon about the city by signaling the police at ferries, bridges, main highways and railroad stations to listen in as the description is broadcast of a bank robber or securities thief or some other man badly wanted, who may be hurrying to get out of the city. It may be used in a given borough or section of the city to reach many precincts with orders to turn out all available men for riot or other emergency duty.

"I believe this is the greatest advance that has yet been made in the application of radio to police work," said Commissioner Enright, who presided over the conference.

Static Unjustly Accused; Thud of Gloves Was Heard



TWO SHORT DANCERS AT WOR, Newark, N. J., during the early gym classes we read about, caused thudding sounds to be emitted from others' horns. Static was blamed, as usual. The girls are Ruth and Grace Stewart, dancers at the Hotel Alamac, New York City. The result was a tie and the title stayed in the family. (Underwood & Underwood.)

SQUIER LOSES AGAIN OVER THE "WIRED" PATENT

Radio Alarm Invented to Aid Police Catch Criminals

ANY patent developed by a Government employe through funds appropriated by Congress belongs to the public, the United States Circuit Court of Appeals ruled in New York City, in denying the appeal of Major-Gen. George O. Squier, former chief signal officer of the United States Army, now retired, in his "wired wireless" suit. The higher tribunal made its decision unanimous and upheld Federal Judge Knox, who had ruled against Squier in the District Court.

Millions of dollars were involved in the decision handed down. The suit involved as a defendant the American Telephone & Telegraph Company, The Westinghouse Electric & Manufacturing Company, the Radio Corporation of America, the General Electric and the Western Electric Company were also interested because of their activities in the development of "wired wireless," or the multiple telephone device.

Through the device, several messages can be transmitted over one wire, instead of one message at a time.

The decision affects, it is said, hundreds of patents now in the Patent Office—the sole work of men attached to the army, navy and marine corps. It also involves other governmental departments where employees have worked out devices which they have patented.

Circuit Judges Hough, Rogers and Manton heard the arguments on appeal. Major-Gen. Squier, as a major during 1909 and 1911, was assigned to do research work in wireless telegraphy for which there had been made available an appropriation by Congress amounting to \$30,000, the decision stated. When the officer had accomplished "wired wireless," he had it patented under the act of 1883, which provided that "it would be free to the public."

Commenting on this phase of the evidence the decision stated that "the plaintiff's own acts and his own words prevented him from recovering." Judge Hough expressed the opinion that Major-Gen. Squier, after proclaiming an intent to give the invention to the public, approved statements to the public press regarding his achievement and the benefits the public would derive from the same.

"Of course, the very existence of the suit shows the fit of public spirit has passed," said Judge Hough. "We are satisfied that the plaintiff wished to be generous in 1911. That he should regret that generous emotion is immaterial."

Major-Gen. Squier asked for an accounting of the profits which the A. T. & T. Co. had made since it had been using "wired wireless," and also prayed for an injunction against infringement upon his patent in the original suit, which he lost. He contended that the Government had a perfect right to utilize his patent, but that private use by any corporation or independent business concern was an infringement upon his rights.

COMPLETE LIST OF STATIONS

Brought up to date and published in RADIO WORLD dated May 2. All American, Canadian, Mexican and Cuban stations in this issue. 15c copy, or start your subscription with any number. RADIO WORLD, 1493 Broadway, New York City.

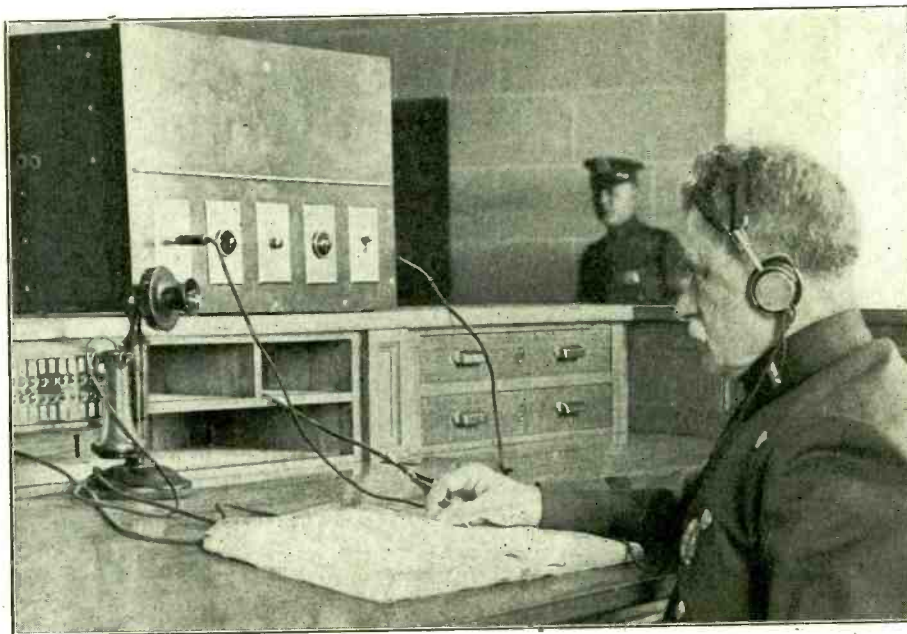

THE NEW POLICE RADIO ALARM—To left and right of the center plug are the signal lights. These are actuated from Police Headquarters. The light may be flashed at a single station, at several stations or at all stations at once. It means: "Listen in! An important police warning will be broadcast!" The device was demonstrated at the Police Conference. (Fotograms.)

THE International Police Conference saw a selective radio signaling system demonstrated in New York City as worked out by the Western Electric Company for Police Headquarters, using Station WNYC. The device can light a signal at any police station or police booth in the city, light the signals in all of them at the same time or light the signals in selected precincts.

This signal can be used to notify every precinct and booth in town simultaneously that something demanding general police attention is about to be broadcast by WNYC, so they may listen in. It may be used to

throw a radio cordon about the city by signaling the police at ferries, bridges, main highways and railroad stations to listen in as the description is broadcast of a bank robber or securities thief or some other man badly wanted, who may be hurrying to get out of the city. It may be used in a given borough or section of the city to reach many precincts with orders to turn out all available men for riot or other emergency duty.

"I believe this is the greatest advance that has yet been made in the application of radio to police work," said Commissioner Enright, who presided over the conference.

Static Unjustly Accused; Thud of Gloves Was Heard



TWO SHORT ROUNDS AT WOR, Newark, N. J., during the early gym classes we read about, caused thudding sounds to be emitted from others' horns. Static was blamed, as usual. The girls are Ruth and Grace Stewart, dancers at the Hotel Alamac, New York City. The result was a tie and the title stayed in the family. (Underwood & Underwood.)

SIX SPEAKER CIRCUITS THAT C

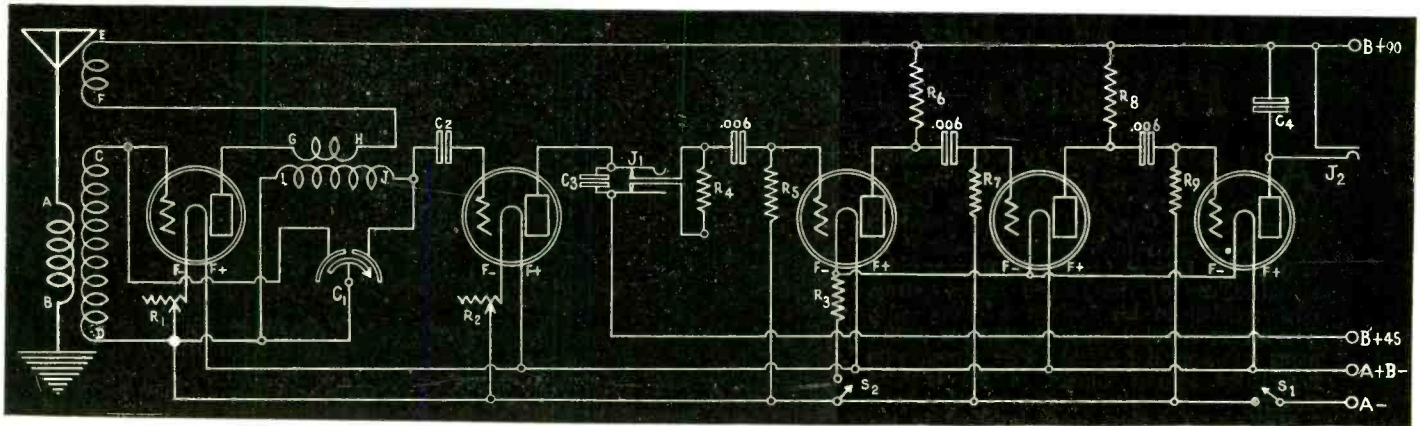

FIG. 1—Where regeneration is used, one RF stage is about all that can be used with dependable success. The above circuit uses a double condenser, having a single rotor and two separate stators, each section .0005 mfd. The regeneration is in the RF stage. The commercial types of 3-circuit coil works nicely here. The RFT should have about the same inductance as the primary and secondary of the 3-circuit coil, respectively. The set is great for DX and as resistance-coupled AF is used, the volume is good and the quality superb. The coils if home-made may be of No. 24 DSC wire, 10-turn primaries, 43-turn secondaries, on $\frac{3}{4}$ " diameter tubings. The tickler would have 30 turns of No. 26 SSC wire on a $\frac{2}{4}$ " diameter. See Fig. 2 for audio resistor values.

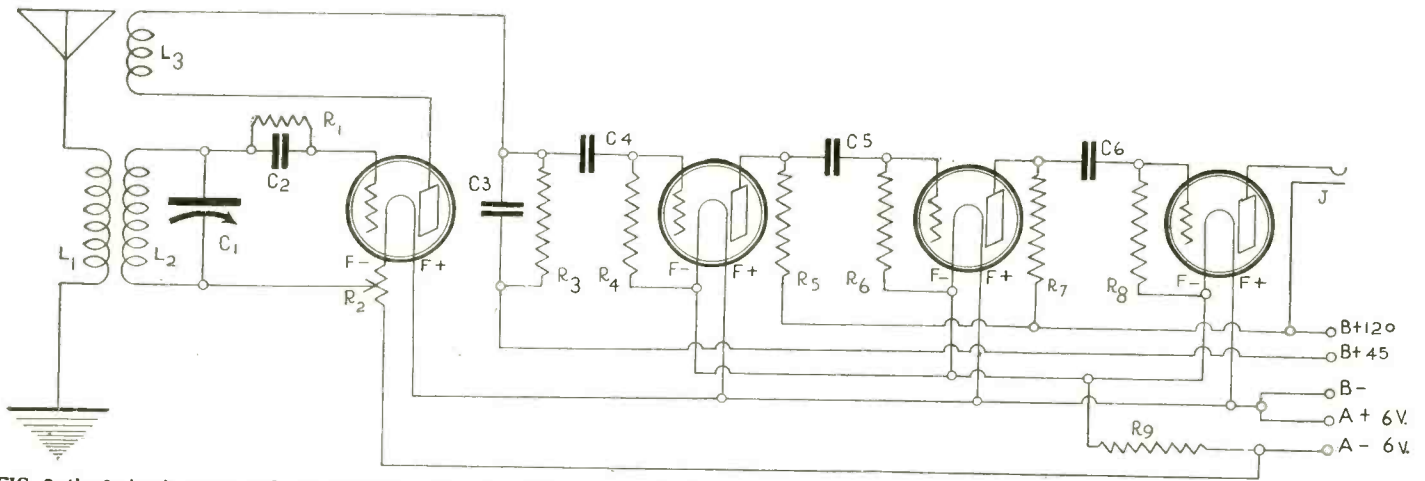

FIG. 2, the 3-circuit tuner, with rotary tickler coil, resistance-coupled audio being used because of the splendid quality it affords. This is fundamentally the Fig. 1 circuit with the RF stage omitted. The same kind of coil may be used for L1L2L3 here as in Fig. 1. C1 is .0005. Use UV201A, C301A or DV2 for the audio stages. These require a 6-volt storage battery. R3, R5 and R7 are 100,000 ohms (1/10 meg.), while R4 is .0005. R6 is 500,000 ohms ($\frac{1}{2}$ meg.); R8, 250,000 ohms ($\frac{1}{4}$ meg.). R9 is a ballast resistance (Daven) for controlling the filaments of three tubes at once. C4, C5 and C6 are .006 mfd. each. C3 is important here. It is .002. Use a higher plate voltage than usual on the detector. On the audio plates 90 to 135 will do the work, 90 being all right.

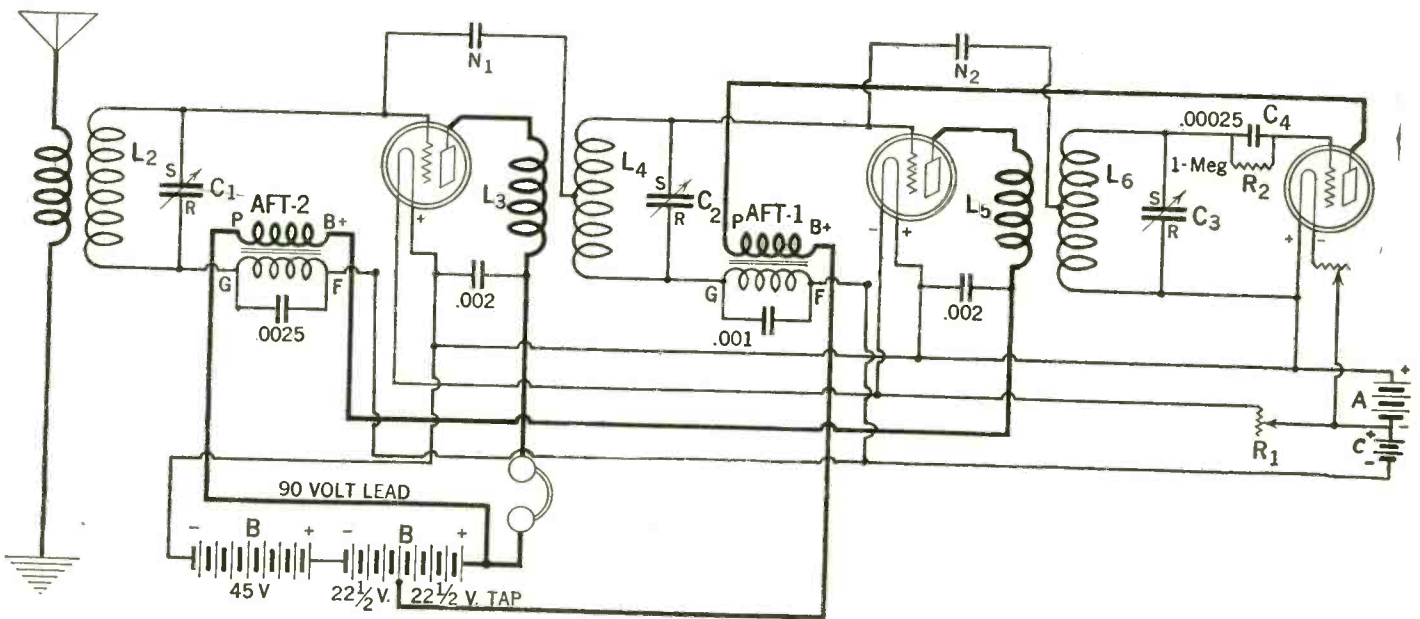

FIG. 6—Only three tubes are used here, but audio amplification is obtained in great volume. This is the 3-tube reflexed Neurodyne, embodying the two tuned RF stages into which are reflexed the audio stages, but in reverse fashion, that is, first AF in second RF and second AF in first RF. This is a hard circuit for the novice and indeed may give the tried experimenter some anxious and interesting moments. But it is a thoroughly practical set and has given wonderful results to the favored ones. The Neurodyne does not radiate and it is simpler to tune, because of quietness attending dial operation, than any of the other circuits on this page. As the set is recommended only to experienced fans, no detailed information as to the Neuroformers, etc., is given here.

ACTIVATED DISCERNING FANS

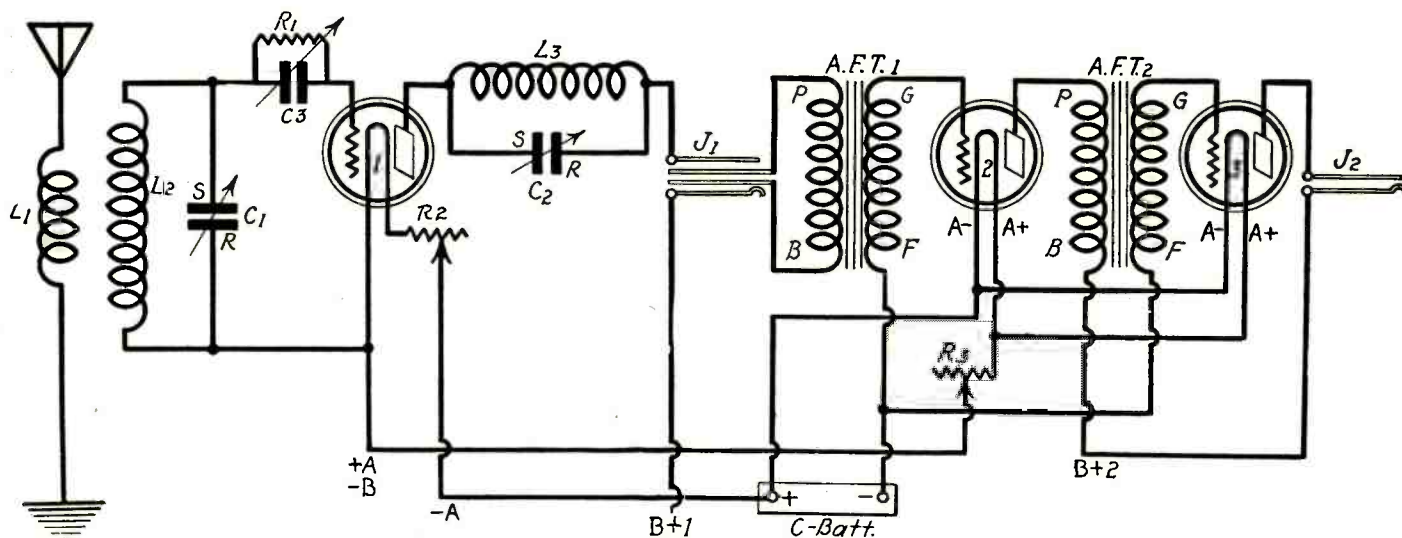

FIG. 4, Bernard's famous 3-Circuit Tuner You Can Log. This is a very simple circuit to construct and indeed an efficient and attractive one. L1L2 may be honeycomb coils, likewise L3. If C1 and C2 are .0005 mfd., then L2 is a 65-turn coil, L1 a 10-turn winding placed over or inside it, the ten turns removed from the 75-turn HC being available. C2 should be 75 full turns, but turns should be taken off, one at a time, until the two condensers tune in step. This they should do for most of the dial readings, but can not be expected to tune instep all the way through. But from one end of the dials to the other the set can be logged, every station coming in at the same readings time and time again. A C battery is inserted in the audio stages to conserve B battery consumption and increase tube efficiency (if the tubes are weakening with age).

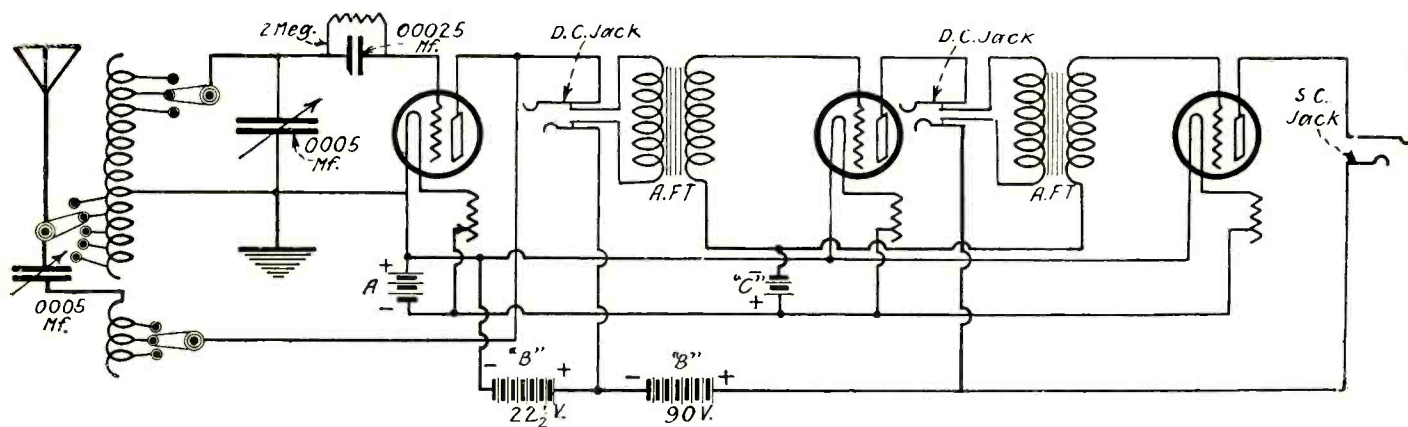

FIG. 5—One of the most satisfactory of radio receivers is the Reinartz set as designed by John L. Reinartz, originator of the new short-wave receiver. The most important part of the set is the special spider weave form. The coil is wound with No. 22 DCC wire, in a spider web design on nine spokes, around a 2 1/2" center, the complete coil being 5 1/2" outside diameter. Starting from the center, wind 15 turns and take a tap off, continue winding 15 more turns and take another tap off, continue winding 15 more turns and take the final tap off. Cut the wire off and begin to wind the other coil (wrap a piece of wire on spoke for holding) which consists of 40 turns tapped in the following fashion (all winding in the same direction): A tap is brought out after the second turn, continue winding 2 more turns, bring another tap out, continue winding and tap every two turns until the 8th turn is reached; take a tap off the coil at the ninth turn; and at the tenth turn. Continue winding 15 more turns and take off another tap, the wiring being continued until 5 more turns have been added and continue the winding for ten more turns, taking off the last tap which is at the 40th turn. You now have eleven taps on the outside coil and four taps on the inner coil. If the audio amplifiers do not work successfully, insert a 75-turn honeycomb coil in the plate circuit of the detector tube.

How the Six Circuits Compare

ON this page are published six circuits. One of them (Fig. 3) uses two tubes and is a reflex, operating a speaker on local stations only. Three of them are 3-tube sets—Fig. 4, the 3-Circuit Tuner You Can Log; Fig. 5, the Reinartz and Fig. 6, the reflexed Neutrodyne. Fig. 6 embodies the conventional stages and includes the inverse duplex method. It is no easy set to build. Fig. 1 is a stage of regenerative RF ahead of a non-regenerative detector, and Fig. 2 is the 3-circuit tuner (not loggable as to tickler), with rotary tickler instead of condenser-tuned plate. Both of these are followed by resistance-coupled AF. For the novice Fig. 4 will prove most attractive, since it is the easiest to build and the most economical for local and DX speaker operation. The extra tube required by resistance AF is well worth while to those who enjoy quality reception. Except in the resistance-coupled audio stages, any oscillating tubes may be used. But the larger tubes

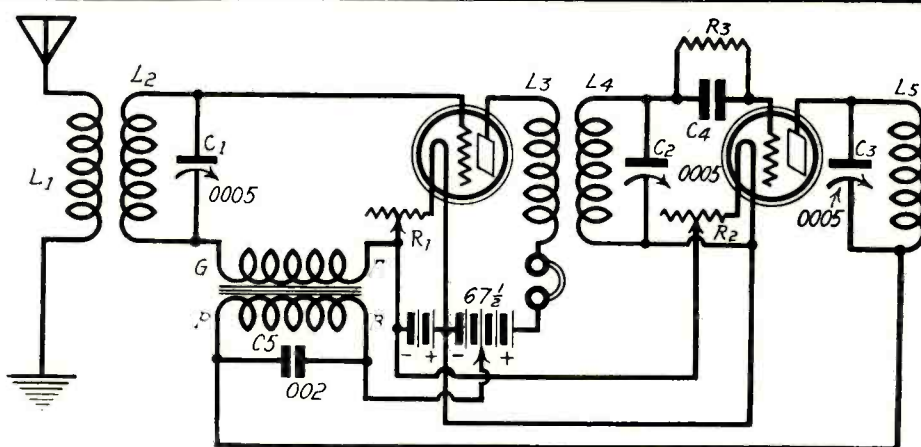

FIG. 3—While this circuit will work a speaker, it will do so only on locals, say stations less than eight miles away. But it is a wonderful earphone reflex, being able to get distance consistently. It comprises a stage of RF, detector and a stage of reflexed AF. Astatic windings are preferred, but the coil directions given in Fig. 1 may be applied, L5 having two more turns than the secondary (L2) of the RFT. The tuned plate method is used to obtain regeneration.

give more volume and hence come in handier in the resistance sets, because the total volume from the resistance ampli-

fier, while it may occasionally be as great as from the two-stage transformer-coupled type, is not greater.

THE KEY TO THE AIR

KEY

Abbreviations: E. S. T., Eastern Standard Time; C. S. T., Central Standard Time; M. S. T., Mountain Standard Time; P. S. T., Pacific Standard Time; D. S., Daylight Saving Time.

How to tune in a desired distant station at just the right time—Choose your station from the list published herewith. See what time division the station is under (E. S. T., C. S. T., etc.); then consult the table below. Add to or subtract, as directed from the time as given on the PROGRAM. The result will be the same BY YOUR CLOCK that you should tune in, unless daylight saving time intervenes, as explained below.—The table:

If you are in	And want a station in	Subtract	Add
E. S. T.	C. S. T.		1 hr.
E. S. T.	M. S. T.		2 hrs.
E. S. T.	P. S. T.		3 hrs.
C. S. T.	E. S. T.	1 hr.	
C. S. T.	M. S. T.		1 hr.
C. S. T.	P. S. T.		2 hrs.
M. S. T.	E. S. T.	2 hrs.	
M. S. T.	C. S. T.	1 hr.	
M. S. T.	P. S. T.		1 hr.
P. S. T.	E. S. T.	3 hrs.	
P. S. T.	C. S. T.	2 hrs.	
P. S. T.	D. S. T.	1 hr.	

If you are under Daylight Saving Time, and the station you want is under that time, too, or if both are under Standard Time, the above table will hold.

If you are under Daylight Saving Time, and the station operates under Standard Time, add one hour to the table result.

If the station uses Daylight Saving Time, and you are under Standard Time, subtract one hour from the table result.

Friday

- WAAM, Newark, N. J., 263 (E. S. T., D. S.)—11 A. M. to 12.
- WAHG, Richmond Hill, N. Y., 316 (E. S. T., D. S.)—12 to 1:05 P. M.; 8 to 12 P. M.
- WAMD, Minneapolis, Minn., 243.8 (C. S. T.)—12 to 1 P. M.; 10 to 12.
- WBBM, Chicago, Ill., 226 (C. S. T.)—8 to 10 P. M.
- WBBR, New York City, 272.6 (E. S. T., D. S.)—8 P. M. to 10.
- WBZ, Springfield, Mass., 333.1 (E. S. T., D. S.)—6 P. M. to 11.
- WCCO, St. Paul and Minneapolis, Minn., 416.4 (C. S. T.)—9:30 A. M. to 12 M.; 1:30 to 4; 5:30 to 10.
- WCAE, Pittsburgh, Pa., 461.3 (E. S. T., D. S.)—12:30 to 1:30 P. M.; 4:30 to 5:30; 6:30 to 11.
- WDAF, Kansas City, Kansas, 365.8 (C. S. T.)—3:30 to 7 P. M.; 8 to 10; 11:45 to 1 A. M.
- WEAF, New York City, 492 (E. S. T., D. S.)—6:45 A. M. to 7:45; 11 to 12; 4 P. M. to 5; 6 to 12.
- WEAR, Cleveland, O., 390 (E. S. T.)—11:30 A. M. to 12:10 P. M.; 3:30 to 4:10; 8 to 11.
- WEAO, Ohio State University, 293.9 (E. S. T.)—8 P. M. to 10.
- WEEL, Boston, Mass., 476 (E. S. T., D. S.)—6:45 A. M. to 7:45; 2 P. M. to 3:15; 5:30 to 10.
- WEMC, Berrien Springs, Mich., 286 (C. S. T.)—9 P. M. to 11.
- WFAA, Dallas, Texas, 475.9 (C. S. T.)—10:30 A. M. to 11:30; 12:30 P. M. to 1; 2:30 to 6; 6:45 to 7; 8:30 to 9:30.
- WGBS, New York City, 316 (E. S. T., D. S.)—10 A. M. to 11; 1:30 P. M. to 4; 6 to 11.
- WGR, Buffalo, N. Y., 319 (E. S. T., D. S.)—12 M. to 12:45 P. M.; 7:30 to 11.
- WGST, Atlanta, Ga., 270 (C. S. T.)—7 P. M. to 8.
- WGY, Schenectady, N. Y., 379.5 (E. S. T.)—1 P. M. to 2; 5:30 to 10:30.
- WHAD, Milwaukee, Wis., 275 (C. S. T.)—11 A. M. to 11:30; 6 P. M. to 8.
- WHAS, Louisville, Ky., 399.8 (C. S. T.)—4 P. M. to 5; 7:30 to 9.
- WHN, New York City, 360 (E. S. T., D. S.)—12:30 P. M. to 1; 2:15 to 5; 7 to 11; 12 to 12:30 A. M.
- WHO, Des Moines, Iowa, 526 (C. S. T.)—7:30 P. M. to 9; 11 to 12; 12:30 to 1:30; 4:30 to 5:30; 6:30 to 9:30.
- WIP, Philadelphia, Pa., 508.2 (E. S. T., D. S.)—7 A. M. to 8; 1 P. M. to 2; 3 to 4:50; 6 to 8.
- WJY, New York City, 405 (E. S. T., D. S.)—7:30 P. M. to 11:30.
- WJZ, New York City, 455 (E. S. T., D. S.)—10 A. M. to 11; 1 P. M. to 2; 4 to 6; 7 to 10:30.
- WLIT, Philadelphia, Pa., 395 (E. S. T.)—12:02 P. M. to 12:30; 2 to 3; 4:30 to 6; 7:30 to 1 A. M.
- WLW, Cincinnati, O., 422.3 (E. S. T.)—10:45 A. M. to 12:15; 1:30 P. M. to 2:30.
- WMCA, New York City, 341 (E. S. T., D. S.)—3 P. M. to 5; 6:30 to 7:30; 8:15 to 8:20; 9 to 10:15; 11 to 11:30.
- WNYC, New York City, 526 (E. S. T., D. S.)—3:45 P. M. to 4:45; 6:20 to 11.
- WOAW, Omaha, Neb., 526 (C. S. T.)—12:30 P. M. to 1; 5:45 to 7:10; 9 to 11.
- WOC, Davenport, Iowa, 484 (C. S. T.)—12:57 P. M. to 2; 3 to 3:30; 5:45 to 12.
- WOR, Newark, N. J., 405 (E. S. T., D. S.)—6:45 A. M. to 7:45; 2:30 P. M. to 4; 6:15 to 7.
- WPAK, Fargo, N. D., 283 (C. S. T.)—7:30 P. M. to 9.
- WPG, Atlantic City, N. J., 299.8 (E. S. T., D. S.)—7 P. M. to 8:30; 10 to 12.
- WQJ, Chicago, Ill., 448 (C. S. T.)—11 A. M. to 12 M.; 3 P. M. to 4; 7 to 8; 10 to 2 A. M.

Saturday

- WAAM, Newark, N. J., 263 (E. S. T.)—7 P. M. to 11.
- WAHG, Richmond Hill, N. Y., 316 (E. S. T., D. S.)—12 M. to 2 A. M.
- WAMD, Minneapolis, Minn., 243.8 (C. S. T.)—12 M. to 1 P. M.; 10 to 12.
- WBBM, Chicago, Ill., 226 (C. S. T.)—8 P. M. to 1 A. M.
- WBBR, New York City, 272.6 (E. S. T., D. S.)—8 P. M. to 9.
- WBZ, Springfield, Mass., 333.1 (E. S. T., D. S.)—11 A. M. to 12:30 P. M.; 7 to 9.
- WCAE, Pittsburgh, Pa., 461.3 (E. S. T., D. S.)—10:45 A. M. to 12 M.; 3 P. M. to 4; 6:30 to 7:30.
- WCBZ, Zion, Ill., 344.6 (C. S. T.)—8 P. M. to 10.
- WCCO, St. Paul and Minneapolis, Minn., 416.4 (C. S. T.)—9:30 A. M. to 12:30 P. M.; 2:30 to 5; 6 to 10.
- WEAF, New York City, 492 (E. S. T., D. S.)—6:45 A. M. to 7:45; 4 P. M. to 5; 6 to 12.
- WEEL, Boston, Mass., 476 (E. S. T., D. S.)—6:45 A. M. to 7 A. M.
- WEAR, Cleveland, O., 390 (E. S. T.)—11:30 A. M. to 12:10 P. M.; 3:30 to 4:10; 7 to 8.
- WEMC, Berrien Springs, Mich., 286 (C. S. T.)—11 A. M. to 12:30 P. M.; 8:15 to 11.
- WFAA, Dallas, Texas, 475.9 (C. S. T.)—12:30 P. M. to 1; 6 to 7; 8:30 to 9:30; 11 to 12:30 A. M.
- WGBS, New York City, 316 (E. S. T., D. S.)—10 A. M. to 11; 1:30 P. M. to 3; 6 to 12.
- WGR, Buffalo, N. Y., 319 (E. S. T., D. S.)—12 M. to 12:45 P. M.; 2:30 to 4:30; 7:30 to 8.
- WGY, Schenectady, N. Y., 379.5 (E. S. T.)—7:30 P. M. to 10.
- WHAD, Milwaukee, Wis., 275 (C. S. T.)—11 A. M. to 11:30; 6 P. M. to 8.
- WHAS, Louisville, Ky., 399.8 (C. S. T.)—4 P. M. to 5; 7:30 to 9.
- WHN, New York City, 360 (E. S. T., D. S.)—2:15 P. M. to 5; 7:30 to 10.
- WHO, Des Moines, Iowa, 526 (C. S. T.)—11 A. M. to 12:30 P. M.; 4 to 5:30; 7:30 to 8:30.
- WIP, Philadelphia, Pa., 508.2 (E. S. T., D. S.)—7 A. M. to 8; 10:20 to 11; 1 P. M. to 2; 3 to 4; 6 to 11:30.
- WJY, New York City, 405 (E. S. T., D. S.)—2:30 P. M. to 5; 8 to 10:30.
- WJZ, New York City, 455 (E. S. T., D. S.)—9 A. M. to 12:30 P. M.; 2:30 to 4; 7 to 10.
- WKRC, Cincinnati, O., 326 (E. S. T.)—10 to 12 M.
- WLW, Cincinnati, O., 422.3 (E. S. T.)—9:30 A. M. to 12:30 P. M.; 7:30 to 10.
- WMAK, Lockport, N. Y., 265.5 (E. S. T.)—10:25 A. M. to 12:30 P. M.
- WMC, Memphis, Tenn., 499.7 (E. S. T.)—7:30 P. M. to 10.
- WMCA, New York City, 341 (E. S. T., D. S.)—3 P. M. to 3:15; 3:30 to 5; 8 to 8:15; 8:30 to 8:45; 11 P. M. to 1 A. M.
- WNYC, New York City, 526 (E. S. T., D. S.)—1 P. M. to 3; 7 to 11.
- WOAW, Omaha, Neb., 526 (C. S. T.)—9 A. M. to 11; 2:15 P. M. to 4; 9 to 11.
- WOC, Davenport, Iowa, 484 (C. S. T.)—12:57 P. M. to 2; 5:45 to 7:10; 9 to 12.
- WOO, Philadelphia, Pa., 508.2 (E. S. T., D. S.)—11 A. M. to 1 P. M.; 4:40 to 5; 10:55 to 11:02.
- WOR, Newark, N. J., 405 (E. S. T., D. S.)—6:45 A. M. to 7:45; 2:30 P. M. to 4; 6:15 to 7:30; 8 to 11.
- WPG, Atlantic City, N. J., 299.8 (C. S. T.)—7 P. M. to 12.
- WQJ, Chicago, Ill., 448 (C. S. T.)—11 A. M. to 12 M.; 3 P. M. to 4; 7 to 8; 10 to 3 A. M.
- WRC, Washington, D. C., 469 (E. S. T.)—4:30 to 5:30 P. M.; 6:45 to 12.

- WWJ, Detroit, Mich., 352.7 (E. S. T.)—11 A. M. to 12:30 P. M.; 2 to 3; 7:20 to 10:30.
- KDKA, Pittsburgh, Pa., 309 (E. S. T.)—10 A. M. to 12:30 P. M.; 1:30 to 6:30; 8:45 to 10.
- KFI, Los Angeles, Cal., 467 (P. S. T.)—5 P. M. to 11.
- KFKX, Hastings, Neb., 288.3 (C. S. T.)—12:30 P. M. to 1:30; 9:30 to 12:30.
- KFNF, Shenandoah, Iowa, 266 (C. S. T.)—12:15 P. M. to 1:15; 3 to 4; 6:30 to 10:30.
- KFOA, Seattle, Wash., 455 (P. S. T.)—Silent.
- KGO, Oakland, Cal., 361.2 (P. S. T.)—11 A. M. to 12:30 P. M.; 3:30 to 5:45; 7:30 to 9.
- KGW, Portland, Oregon, 491.5 (P. S. T.)—11:30 A. M. to 1:30 P. M.; 6 to 7; 10 to 11.
- KHJ, Los Angeles, Cal., 405.2 (E. S. T., D. S.)—7 A. M. to 7:30; 10 to 1:30 P. M.; 2:30 to 3:30; 5:30 to 2 A. M.
- KNX, Hollywood, Cal., 337 (P. S. T.)—1 P. M. to 2; 6:30 to 2 A. M.
- KOA, Denver, Colo., 322.4 (M. S. T.)—11:30 A. M. to 1 P. M.; 7 to 10.
- KPO, San Francisco, Cal., 429 (P. S. T.)—8 A. M. to 12 M.; 2 P. M. to 3; 6 to 10.
- KSD, St. Louis, Mo., 545.1 (C. S. T.)—7 P. M. to 8:30.
- KTHS, Hot Springs, Ark., 374.8 (C. S. T.)—12:30 P. M. to 1; 8:30 to 10:30.
- KYW, Chicago, Ill., 536 (C. S. T., D. S.)—11 A. M. to 12:30 P. M.; 4 to 5; 7 to 8.
- CKAC, Montreal, Canada, 411 (E. S. T.)—4:30 P. M. to 5:30.
- CNRO, Ottawa, Ontario, Canada, 435 (E. S. T.)—7:30 P. M. to 10.
- PWX, Havana, Cuba, 400 (E. S. T.)—8:30 P. M. to 11:30.

Sunday

- WBBM, Chicago, Ill., 226 (C. S. T.)—4 P. M. to 6; 8 to 10.
- WBBR, New York City, 272.6 (E. S. T., D. S.)—10 A. M. to 12 M., 9 P. M. to 11.
- WCCO, St. Paul and Minneapolis, Minn., 416.4 (C. S. T.)—11 A. M. to 12:30 P. M.; 4:10 to 5:10; 7:20 to 10.
- WDAF, Kansas City, Kansas, 365.6 (C. S. T.)—4 P. M. to 5:30.
- WEAF, New York City, 492 (E. S. T., D. S.)—3 P. M. to 5; 7:20 to 10:15.
- WEAR, Cleveland, O., 390 (E. S. T.)—3:30 P. M. to 5; 7 to 8; 9 to 10.
- WGR, Buffalo, N. Y., 319 (E. S. T., D. S.)—3 P. M. to 4; 7:15 to 8.
- WGBS, New York City, 316 (E. S. T., D. S.)—3:30 P. M. to 4:30; 9:30 to 10:30.
- WGY, Schenectady, N. Y., 379.5 (E. S. T.)—9:30 A. M. to 12:30 P. M.; 2:35 to 3:45; 6:30 to 10:30.
- WHAD, Milwaukee, Wis., 275 (C. S. T.)—2 P. M. to 3.
- WHN, New York City, 360 (E. S. T., D. S.)—1 P. M. to 1:30; 3 to 6; 10 to 12.
- WIP, Philadelphia, Pa., 508.2 (E. S. T., D. S.)—10:45 A. M. to 12:30 P. M.; 3:30 to 4:30.
- WKRC, Cincinnati, O., 326 (E. S. T.)—6:45 P. M. to 11.
- WNYC, New York City, 526 (E. S. T., D. S.)—9 P. M. to 11.
- WPG, Atlantic City, N. J., 299.8 (C. S. T., D. S.)—3:15 P. M. to 5; 9 to 11.
- WQJ, Chicago, Ill., 448 (C. S. T.)—10:30 A. M. to 12:30 P. M.; 3 P. M. to 4; 8 to 10.
- KFNF, Shenandoah, Iowa, 266 (C. S. T.)—10:45 A. M. to 12:30 P. M.; 2:30 to 4:30; 6:30 to 10.
- KOA, Denver, Colo., 322.4 (M. S. T.)—10:55 A. M. to 12 M.; 4 P. M. to 5:30 P. M.; 7:45 P. M. to 10 P. M.
- KGW, Portland, Oregon, 491.5 (P. S. T.)—10:30 A. M. to 12:30 P. M.; 6 to 9.
- KHJ, Los Angeles, Cal., 405.2 (E. S. T., D. S.)—10 A. M. to 12:30 P. M.; 6 to 9.
- KTHS, Hot Springs, Ark., 374.8 (C. S. T.)—11 A. M. to 12:30 P. M.; 2:30 to 3:40; 8:40 to 11.

Monday

- WAAM, Newark, N. J., 263 (E. S. T., D. S.)—11 A. M. to 12 M.; 7 P. M. to 11.
- WAHG, Richmond Hill, N. Y., 316 (E. S. T., D. S.)—12 M. to 1:05 P. M.; 8 to 2 A. M.
- WAMD, Minneapolis, Minn., 243.8 (C. S. T.)—10 P. M. to 12.
- WBBM, Chicago, Ill., 226 (C. S. T.)—6 P. M. to 7.
- WBBR, New York City, 272.6 (E. S. T., D. S.)—8 P. M. to 9.
- WBZ, Springfield, Mass., 333.1 (E. S. T., D. S.)—6 P. M. to 11:30.
- WCAE, Pittsburgh, Pa., 461.3 (E. S. T., D. S.)—12:30 P. M. to 1:30; 4:30 to 5:30; 6:30 to 12.
- WCBZ, Zion, Ill., 344.6 (C. S. T.)—8 P. M. to 10.
- WCCO, St. Paul and Minneapolis, Minn., 416.4 (C. S. T.)—9:30 A. M. to 12 M.; 1:30 P. M. to 6:15; 8 to 10.
- WDAF, Kansas City, Kansas, 365.6 (C. S. T.)—3:30 P. M. to 7; 8 to 10; 11:45 to 1 A. M.
- WEAF, New York City, 492 (E. S. T., D. S.)—6:45 A. M. to 7:45; 4 P. M. to 5; 6 to 11:30.
- WEAR, Cleveland, O., 390 (E. S. T.)—11:30 A. M. to 12:10 P. M.; 3:30 to 4:10; 7 to 8.
- WEEL, Boston, Mass., 476 (E. S. T., D. S.)—6:45 A. M. to 8; 3 P. M. to 4; 5:30 to 10.
- WEMC, Berrien Springs, Mich., 286 (C. S. T.)—8:15 P. M. to 11.
- WFAA, Dallas, Texas, 475.9 (C. S. T.)—10:30 A. M. to 11:30; 12:30 P. M. to 1; 2:30 to 6; 6:45 to 7; 8:30 to 9:30.
- WGBS, New York City, 316 (E. S. T., D. S.)—10 A. M. to 11; 1:30 P. M. to 3:10; 6 to 7:30.
- WGR, Buffalo, N. Y., 319 (E. S. T., D. S.)—12 M. to 12:30 P. M.; 2:30 to 4:30; 7:30 to 11.
- WGST, Atlanta, Ga., 270 (C. S. T.)—9 P. M. to 10.
- WGY, Schenectady, N. Y., 379.5 (E. S. T.)—1 P. M. to 2; 5:30 to 8:30.

WHAD, Milwaukee, Wis., 275 (C. S. T.)—11 A. M. to 11:30; 6 P. M. to 10:30.
WHAS, Louisville, Ky., 399.8 (C. S. T.)—4 P. M. to 5; 7:30 to 9.
WHN, New York City, 360 (E. S. T., D. S.)—2:15 P. M. to 5; 6:30 to 12.
WHO, Des Moines, Iowa, 526 (C. S. T.)—12:15 P. M. to 1:30; 7:30 to 9; 11:15 to 12.
WIP, Philadelphia, Pa., 508.2 (E. S. T., D. S.)—7 A. M. to 8; 1 P. M. to 2; 3 to 8.
WJZ, New York City, 455 (E. S. T., D. S.)—10 A. M. to 11; 1 P. M. to 2; 4 to 5:30; 6 to 6:30; 7 to 11.
WKRC, Cincinnati, O., 326 (E. S. T.)—8 P. M. to 10.
WLIT, Philadelphia, Pa., 395 (E. S. T.)—12:02 P. M. to 1; 2 to 3; 4:30 to 6; 7:30 to 11:30.
WPAK, Fargo, N. D., 283 (C. S. T.)—7:30 P. M. to 9.
WLW, Cincinnati, O., 422.3 (E. S. T.)—10:45 A. M. to 12:15 P. M.; 1:30 to 2:30; 3 to 5; 6 to 10.
WMAK, Lockport, N. Y., 265.5 (E. S. T.)—8 P. M. to 12.
WNYC, New York City, 526 (E. S. T., D. S.)—3:15 P. M. to 4:15; 6:20 to 11.
WOAW, Omaha, Neb., 526 (C. S. T.)—12:30 P. M. to 1:30; 5:45 to 10:30.
WOC, Davenport, Iowa, 484 (C. S. T.)—12:57 P. M. to 2; 3 to 3:30; 5:45 to 10.
WOO, Philadelphia, Pa., 508.2 (E. S. T., D. S.)—11 A. M. to 1 P. M.; 4:40 to 6; 7:30 to 11.
WOR, Newark, N. J., 405 (E. S. T., D. S.)—6:45 A. M. to 7:45; 2:30 to 4; 6:15 to 11:30.
WPG, Atlantic City, N. J., 299.8 (E. S. T., D. S.)—7 P. M. to 11.
WQJ, Chicago, Ill., 448 (C. S. T.)—11 A. M. to 12 M.; 3 P. M. to 4.
WRC, Washington, D. C., 469 (E. S. T.)—1 P. M. to 2; 4 to 6.
KDKA, Pittsburgh, Pa., 309 (E. S. T.)—6 A. M. to 7; 9:45 to 12:15 P. M.; 2:30 to 3:20; 5:30 to 10.
KFAE, State College of Wash., 348.6 (P. S. T.)—7:30 P. M. to 9.
KFI, Los Angeles, Cal., 467 (P. S. T.)—5 P. M. to 11.
KFKX, Hastings, Neb., 288.3 (C. S. T.)—12:30 P. M. to 1:30; 5:15 to 6:15; 9:30 to 12:30.
KFNF, Shenandoah, Iowa, 266 (C. S. T.)—12:15 P. M. to 1:15; 3 to 4; 6:30 to 10.
KFOA, Seattle, Wash., 455 (P. S. T.)—12:45 P. M. to 1:30; 4 to 5:15; 6 to 10.
KGO, Oakland, Cal., 361.2 (P. S. T.)—9 A. M. to 10:30; 11:30 A. M. to 1 P. M.; 1:30 to 6; 6:45 to 7; 8 to 1 A. M.
KGW, Portland, Oregon, 491.5 (P. S. T.)—11:30 A. M. to 1:30; 5 to 8.
KHJ, Los Angeles, Cal., 405.2 (P. S. T.)—7 A. M. to 7:15; 12 M. to 1:30 P. M.; 5:30 to 10.
KNX, Hollywood, Cal., 337 (P. S. T.)—12 M. to 1 P. M.; 4 to 5; 6:30 to 12.
KOB, State College of New Mexico, 348.6 (M. S. T.)—11:55 A. M. to 12:30 P. M.; 7:30 to 8:30; 9:55 to 10:10.
KPO, San Francisco, Cal., 429 (P. S. T.)—10:30 A. M. to 12 M.; 1 P. M. to 2; 2:30 to 3:30; 4:30 to 10.
KSD, St. Louis, Mo., 545.1 (C. S. T.)—7:30 P. M. to 10.
KTHS, Hot Springs, Ark., 374.8 (C. S. T.)—12:30 P. M. to 1; 8:30 to 10.
KYW, Chicago, Ill., 536 (C. S. T., D. S.)—6:30 A. M. to 7:30; 10:55 to 1 P. M.; 2:15 to 3:30; 6:02 to 7.
WAAM, Newark, N. J., 263 (E. S. T., D. S.)—11 A. M. to 12 M.; 7 P. M. to 11.
WAHG, Richmond Hill, N. Y., 316 (E. S. T., D. S.)—12 P. M. to 1:05 P. M.; 8 to 12.
WAMD, Minneapolis, Minn., 243.8 (C. S. T.)—12 M. to 1 P. M.; 10 to 12.
WBBM, Chicago, Ill., 226 (C. S. T.)—8 P. M. to 12.
WBZ, Springfield, Mass., 333.1 (E. S. T., D. S.)—6 P. M. to 11.
WCAE, Pittsburgh, Pa., 461.3 (E. S. T., D. S.)—12:30 P. M. to 1:30; 4:30 to 5:30; 6:30 to 11.
WCCO, St. Paul and Minneapolis, Minn., 416.4 (C. S. T.)—9:30 A. M. to 12 M.; 1:30 P. M. to 4; 5:30 to 10.
WDAF, Kansas City, Kansas, 365.6 (C. S. T.)—3:30 P. M. to 7; 11:45 to 1 A. M.
WEAF, New York City, 492 (E. S. T., D. S.)—6:45 A. M. to 7:45; 11 to 12 M.; 4 P. M. to 5; 6 to 12.
WEAR, Cleveland, O., 390 (E. S. T.)—11:30 A. M. to 12:10 P. M.; 7 to 10; 10 to 11.
WEEL, Boston, Mass., 476 (E. S. T., D. S.)—6:45 A. M. to 8; 1 P. M. to 2; 6:30 to 10.
WFAA, Dallas, Texas, 475.9 (C. S. T.)—10:30 A. M. to 11:30; 12:30 P. M. to 1; 2:30 to 6; 6:45 to 7; 8:30 to 9:30; 11 to 12.
WGBS, New York City, 316 (E. S. T., D. S.)—10 A. M. to 11; 1:30 P. M. to 3; 6 to 11:30.
WGR, Buffalo, N. Y., 319 (E. S. T., D. S.)—11 A. M. to 12:45 P. M.; 7:30 to 11.
WGY, Schenectady, N. Y., 379.5 (E. S. T.)—11 P. M. to 2:30; 5:20 to 7:30; 9 to 11:30.
WHAD, Milwaukee, Wis., 275 (C. S. T.)—11 A. M. to 11:30; 6 P. M. to 9.
WHAS, Louisville, Ky., 399.8 (C. S. T.)—4 P. M. to 5; 7:30 to 9.
WHN, New York City, 360 (E. S. T., D. S.)—12:30 P. M. to 1; 2:15 to 3:15; 4 to 5:30; 7:30 to 10:45; 11:30 to 12:30 A. M.
WHO, Des Moines, Iowa, 526 (C. S. T.)—12:15 P. M. to 1:30; 7:30 to 9; 11 to 12.
WIP, Philadelphia, Pa., 508.2 (E. S. T., D. S.)—7 A. M. to 8; 1 P. M. to 2; 3 to 4:50; 6 to 11.
WJY, New York City, 405 (E. S. T., D. S.)—7:30 P. M. to 11:30.
WJZ, New York City, 455 (E. S. T., D. S.)—10 A. M. to 11; 1 P. M. to 2; 4 to 6; 7 to 11.
WKRC, Cincinnati, O., 326 (E. S. T.)—8 P. M. to 12.

Tuesday

WLIT, Philadelphia, Pa., 395 (E. S. T.)—11 A. M. to 12:30 P. M.; 2 to 3; 4:30 to 7.
WLW, Cincinnati, O., 422.3 (E. S. T.)—10:45 A. M. to 1 P. M.; 1:30 to 2:30; 3 to 5; 6 to 11.
WNYC, New York City, 526 (E. S. T., D. S.)—3:45 P. M. to 5; 6:50 to 11.
WOAW, Omaha, Neb., 526 (C. S. T.)—12:30 P. M. to 1:30; 5:45 to 11.
WOC, Davenport, Iowa, 484 (C. S. T.)—12:57 P. M. to 2; 3 to 3:30; 5:45 to 10.
WOO, Philadelphia, Pa., 508.2 (E. S. T., D. S.)—11 A. M. to 1 P. M.; 4:40 to 5; 10:55 to 11:02.
WOR, Newark, N. J., 405 (E. S. T., D. S.)—5:45 A. M. to 7:45; 2:30 P. M. to 4; 6:15 to 7:30.
WPG, Atlantic City, N. J., 299.8 (E. S. T., D. S.)—7 P. M. to 11.
WQJ, Chicago, Ill., 448 (C. S. T.)—11 A. M. to 12 M.; 3 P. M. to 4; 7 to 8; 10 to 2 A. M.
WRC, Washington, D. C., 469 (E. S. T.)—4:30 P. M. to 5:30; 6:45 to 11.
KDKA, Pittsburgh, Pa., 309 (E. S. T.)—9:45 P. M. to 12 M.; 1:30 P. M. to 3:20; 5:30 to 10:45.
KFI, Los Angeles, Cal., 467 (P. S. T.)—5 P. M. to 11.
KFKX, Hastings, Neb., 288.3 (C. S. T.)—12:30 P. M. to 1:30; 5:15 to 6:15; 9:30 to 12:30.
KFOA, Seattle, Wash., 455 (P. S. T.)—12:30 P. M. to 1:30; 4 to 5:15; 6 to 11.
KGO, Oakland, Cal., 361.2 (P. S. T.)—11:30 A. M. to 1 P. M.; 1:30 to 3; 4 to 6:45; 8 to 1 A. M.
KGW, Portland, Oregon, 491.5 (P. S. T.)—11:30 A. M. to 1:30 P. M.; 5 to 11.
KHJ, Los Angeles, Cal., 405.2 (P. S. T.)—7 A. M. to 7:15; 12 M. to 3:30 P. M.; 5:30 to 11.
KNX, Hollywood, Cal., 337 (P. S. T.)—9 A. M. to 10; 1 P. M. to 2; 4 to 5; 6:30 to 12.
KPO, San Francisco, Cal., 429 (P. S. T.)—7 A. M. to 7:45; 10 to 12 M.; 1 P. M. to 2; 3:30 to 11.
KSD, St. Louis, Mo., 545.1 (C. S. T.)—6 P. M. to 7.
KTHS, Hot Springs, Ark., 374.8 (C. S. T.)—12:30 P. M. to 1; 8:30 to 10:30.
KYW, Chicago, Ill., 536 (C. S. T., D. S.)—6:30 A. M. to 7:30; 10:30 to 1 P. M.; 2:15 to 4; 6:02 to 11:30.
CNRA, Moncton, New Brunswick, Canada, 313 (E. S. T.)—9:30 P. M. to 11.
CNRR, Regina, Saskatchewan, Canada, 8 P. M. to 11.
WAAM, Newark, N. J., 263 (E. S. T., D. S.)—11 A. M. to 12 M.; 7 P. M. to 11.
WAHG, Richmond Hill, N. Y., 316 (E. S. T., D. S.)—12 M. to 1:05 P. M.; 8 to 12.
WAMD, Minneapolis, Minn., 243.8 (C. S. T.)—12 M. to 1 P. M.; 10 to 12.
WBBM, Chicago, Ill., 226 (C. S. T.)—8 P. M. to 10.
WBZ, Springfield, Mass., 333.1 (E. S. T., D. S.)—6 P. M. to 11.
WCAE, Pittsburgh, Pa., 461.3 (E. S. T., D. S.)—12:30 P. M. to 1:30; 4:30 to 5:30; 6:30 to 11.
WCCO, St. Paul and Minneapolis, Minn., 416.4 (C. S. T.)—9:30 A. M. to 12 M.; 1:30 to 4; 5:30 to 11.
WDAF, Kansas City, Kansas, 365.6 (C. S. T.)—3:30 P. M. to 7; 8 to 9:15; 11:45 to 1 A. M.
WEAF, New York City, 492 (E. S. T., D. S.)—6:45 A. M. to 7:45; 11 to 12 M.; 4 P. M. to 5; 6 to 12.
WEAO, Ohio State University, 293.9 (E. S. T.)—8 P. M. to 10.
WEAR, Cleveland, O., 390 (E. S. T.)—11:30 A. M. to 12:10 P. M.; 3:30 to 4:10; 6:45 to 7:45.
WEEL, Boston, Mass., 476 (E. S. T., D. S.)—6:45 A. M. to 8; 3 P. M. to 4; 5:30 to 10.
WEMC, Berrien Springs, Mich., 226 (C. S. T.)—8:15 P. M. to 11.
WFAA, Dallas, Texas, 475.9 (C. S. T.)—10:30 A. M. to 11:30; 12:30 P. M. to 1.
WGBS, New York City, 316 (E. S. T., D. S.)—10 A. M. to 11 P. M.; 1:30 to 4; 6 to 7.
WGR, Buffalo, N. Y., 319 (E. S. T., D. S.)—12 M. to 12:45 P. M.; 2:30 to 4:30; 6:30 to 11.
WGY, Schenectady, N. Y., 379.5 (C. S. T.)—5:30 P. M. to 7:30.
WHAD, Milwaukee, Wis., 275 (C. S. T.)—11 A. M. to 11:30; 4 P. M. to 5; 6 to 10; 11:30 to 12:30 A. M.
WHAS, Louisville, Ky., 399.8 (C. S. T.)—4 P. M. to 5; 7:30 to 9.
WHN, New York City, 360 (E. S. T., D. S.)—2:15 P. M. to 5:30; 7:30 to 11; 11:30 to 12:30 A. M.
WHO, Des Moines, Iowa, 526 (C. S. T.)—12:15 P. M. to 1:30; 6:30 to 12 M.
WIP, Philadelphia, Pa., 508 (E. S. T., D. S.)—7 A. M. to 8; 10:20 to 11; 1 P. M. to 2; 3 to 4; 6 to 8.
WJZ, New York City, 455 (E. S. T., D. S.)—10 A. M. to 11; 1 P. M. to 2; 4 to 6; 7 to 11:30.
WKRC, Cincinnati, Ohio, 326 (E. S. T.)—8 P. M. to 10.
WLIT, Philadelphia, Pa., 395 (E. S. T.)—12:02 P. M. to 12:30; 2 to 3; 4:30 to 9.
WLW, Cincinnati, O., 422.3 (E. S. T.)—10:45 A. M. to 12:15 P. M.; 1:30 to 2:30; 3 to 5; 6 to 11.
WNYC, New York City, 526 (E. S. T., D. S.)—6:30 P. M. to 11.
WOC, Davenport, Iowa, 484 (C. S. T.)—12:57 P. M. to 2; 3 to 3:30; 4 to 7:05; 9 to 11.
WOR, Newark, N. J., 405 (E. S. T., D. S.)—6:45 A. M. to 7:45; 2:30 P. M. to 4; 6:15 to 12 M.
WPAK, Fargo, N. D., 283 (C. S. T.)—7:30 P. M. to 9.
WQJ, Chicago, Ill., 448 (C. S. T.)—11 A. M. to 12 M.; 3 P. M. to 4; 7 to 8; 10 to 2 A. M.
WRC, Washington, D. C., 469 (E. S. T.)—1 P. M. to 2; 4 to 6:30.
KDKA, Pittsburgh, Pa., 309 (E. S. T.)—6 A. M. to 7; 9:45 to 12:15 P. M.; 2:30 to 3:20; 5:30 to 11.
KFAE, State College of Wash., 348.6 (P. S. T.)—7:30 P. M. to 9.

Wednesday

KFI, Los Angeles, Cal., 467 (P. S. T.)—5 P. M. to 11.
KFKX, Hastings, Neb., 288.3 (C. S. T.)—12:30 P. M. to 1:30; 5:15 to 6:15; 9:30 to 12:30.
KFNF, Shenandoah, Iowa, 266 (C. S. T.)—12:15 P. M. to 1:15; 3 to 4; 6:30 to 10.
KFOA, Seattle, Wash., 455 (P. S. T.)—12:30 P. M. to 1:30; 4 to 5:15; 6 to 10.
KGO, Oakland, Cal., 361.2 (P. S. T.)—11:30 A. M. to 1 P. M.; 1:30 to 2:30; 3 to 6:45.
KGW, Portland, Oregon, 491.5 (P. S. T.)—11:30 A. M. to 1:30 P. M.; 5 to 10.
KHJ, Los Angeles, Cal., 405.2 (P. S. T.)—7 A. M. to 7:15; 12 M. to 1:30 P. M.; 5:30 to 12.
KNX, Hollywood, Cal., 337 (P. S. T.)—1 P. M. to 2; 7 to 12.
KOB, State College of New Mexico, 348.6 (M. S. T.)—11:55 A. M. to 12:30 P. M.; 7:30 to 8:30; 9:55 to 10:10.
KPO, San Francisco, Cal., 429 (P. S. T.)—7 A. M. to 8; 10:30 to 12 M.; 1 P. M. to 2; 4:30 to 11.
KSD, St. Louis, Mo., 545.1 (C. S. T.)—7 P. M. to 10.
KTHS, Hot Springs, Ark., 374.8 (C. S. T.)—8:30 P. M. to 10.
KYW, Chicago, Ill., 536 (C. S. T., D. S.)—6:30 A. M. to 7:30; 10:55 to 1 P. M.; 2:15 to 4; 6:02 to 11:30.
PWX, Havana, Cuba, 400 (E. S. T.)—8:30 P. M. to 11:30.
CNRO, Ottawa, Ontario, Canada, 435 (E. S. T.)—7 P. M. to 11.
WAAM, Newark, N. J., 263 (E. S. T., D. S.)—11 A. M. to 12 M.; 7 P. M. to 11.
WAHG, Richmond Hill, N. Y., 316 (E. S. T.)—12 P. M. to 1:05.
WAMB, Minneapolis, Minn., 243.8 (C. S. T.)—12 M. to 1 P. M.; 10 to 12 M.
WBBM, Chicago, Ill., 226 (C. S. T.)—8 P. M. to 10.
WBZ, Springfield, Mass., 333.1 (E. S. T., D. S.)—6 P. M. to 11:45.
WCAE, Pittsburgh, Pa., 461.3 (C. S. T., D. S.)—12:30 P. M. to 1:30; 4:30 to 5:30; 6:30 to 11.
WCBD, Zion, Ill., 344.6 (C. S. T.)—8 P. M. to 10.
WCCO, St. Paul and Minneapolis, Minn., 416.4 (C. S. T.)—9:30 A. M. to 12 M.; 1:30 P. M. to 4; 5:30 to 10.
WEAF, New York City, 492 (E. S. T., D. S.)—6:45 A. M. to 7:45; 11 to 12 M.; 4 P. M. to 5; 6 to 12.
WEAR, Cleveland, O., 390 (E. S. T.)—10:30 A. M. to 12:10 P. M.; 3:30 to 4:15; 7 to 11.
WEEL, Boston, Mass., 476 (E. S. T., D. S.)—6:45 A. M. to 7:45; 1 P. M. to 2; 2:30 to 10.
WFAA, Dallas, Texas, 475.9 (C. S. T.)—10:30 A. M. to 11:30; 12:30 P. M. to 1; 2:30 to 6; 6:45 to 7; 8:30 to 9:30; 11 to 1 A. M.
WGBS, New York City, 316 (E. S. T., D. S.)—10 A. M. to 11; 1:30 P. M. to 4; 6 to 7:30.
WGR, Buffalo, N. Y., 319 (E. S. T., D. S.)—12 M. to 12:45 P. M.; 2 to 4; 7:30 to 11.
WHAD, Milwaukee, Wis., 275 (C. S. T.)—11 A. M. to 11:30; 6 P. M. to 7:15; 8:30 to 11.
WHAS, Louisville, Ky., 399.8 (C. S. T.)—4 P. M. to 5; 7:30 to 9.
WHN, New York City, 360 (E. S. T., D. S.)—2:15 P. M. to 5; 7:30 to 11; 11:30 to 12:30 A. M.
WHO, Des Moines, Iowa, 526 (C. S. T.)—7:30 P. M. to 9; 11 to 12 M.
WJY, New York City, 405 (E. S. T., D. S.)—7:30 P. M. to 11:30.
WJZ, New York City, 455 (E. S. T., D. S.)—10 A. M. to 11 P. M.; 1 to 2; 4 to 6; 7 to 12 M.
WLIT, Philadelphia, Pa., 395 (E. S. T.)—12:02 P. M. to 12:30; 2 to 3; 4:30 to 9.
WLW, Cincinnati, O., 422.3 (E. S. T.)—10:45 A. M. to 12:15 P. M.; 1:30 to 2:30; 3 to 5; 6 to 11.
WNYC, New York City, 526 (E. S. T., D. S.)—6:30 P. M. to 11.
WOC, Davenport, Iowa, 484 (C. S. T.)—12:57 A. M. to 2 P. M.; 3 to 3:30; 4 to 7:10; 8 to 9.
WOR, Newark, N. J., 405 (E. S. T., D. S.)—6:45 A. M. to 7:45; 2:30 P. M. to 4; 6:15 to 7.
WPG, Atlantic City, N. J., 299.8 (E. S. T., D. S.)—7 P. M. to 11.
WQJ, Chicago, Ill., 448 (C. S. T.)—11 A. M. to 12 M.; 3 P. M. to 4; 7 to 8; 10 to 2 A. M.
WRC, Washington, D. C., 469 (E. S. T.)—1 P. M. to 2; 4 to 6:30.
KDKA, Pittsburgh, Pa., 309 (E. S. T.)—9:45 A. M. to 12:15 P. M.; 2:30 to 3:20; 5:30 to 10:15.
KFAE, State College of Washington, 348.6 (P. S. T.)—7:30 P. M. to 9.
KFI, Los Angeles, Cal., 467 (P. S. T.)—5 P. M. to 11.
KFKX, Hastings, Neb., 288.3 (C. S. T.)—12:30 P. M. to 1:30; 5:15 to 6:15; 9:30 to 12:30.
KFNF, Shenandoah, Iowa, 266 (C. S. T.)—12:15 to 1:15 P. M.; 3 to 4; 6:30 to 10.
KFOA, Seattle, Wash., 455 (P. S. T.)—12:30 P. M. to 1:30; 4 to 5:15; 6 to 7.
KGO, Oakland, Cal., 361.2 (P. S. T.)—11:30 A. M. to 1 P. M.; 1:30 to 3; 4 to 6:45; 7:15 to 10.
KGW, Portland, Oregon, 491.5 (P. S. T.)—11:30 A. M. to 1:30 P. M.; 5 to 11.
KHJ, Los Angeles, Cal., 405.2 (P. S. T.)—7 A. M. to 7:15; 12 M. to 3:20; 5:30 to 11:30.
KNX, Hollywood, Cal., 337 (P. S. T.)—11 A. M. to 12:05 P. M.; 4 to 5; 6 to 12.
KPO, San Francisco, Cal., 429 (P. S. T.)—7 A. M. to 8; 10:30 to 12 M.; 1 P. M. to 2; 3:30 to 11.
KSD, St. Louis, Mo., 595.1 (C. S. T.)—7:30 P. M. to 9.
(Concluded on page 26)

Thursday

A THOUGHT FOR THE WEEK

ETERNAL vigilance is the price of liberty and ease of mind on the part of radio publishers, manufacturers, dealers and fans. Webster defines the word vigilance, in part, as "Caution; Circumspection."

RADIO WORLD

Radio World's Slogan: "A radio set for every home."

TELEPHONES: LACKAWANNA 6976 and 2063
 PUBLISHED EVERY WEDNESDAY
 (Dated Saturday of same week)
 FROM PUBLICATION OFFICE
HENNESSY RADIO PUBLICATIONS CORPORATION
 ROLAND BURKE HENNESSY, President
 M. B. HENNESSY, Vice-President
 FRED S. CLARK, Secretary and Manager
 1493 BROADWAY, NEW YORK, N. Y.
 (Putnam Bldg., Times Square and 43rd Street)
 European Representatives: The International News, Co.,
 Breains Bldgs., Chancery Lane, London, Eng.
 France. Brenano's 38 Avenue de l'Opera.

EDITOR, Roland Burke Hennessy
 MANAGING EDITOR, Horman Bernard

SUBSCRIPTION RATES

Fifteen cents a copy. \$6.00 a year. \$3.00 for six months. \$1.50 for three months. Add \$1.00 a year extra for foreign postage. Canada, 50 cents.
 Receipt by new subscribers of the first copy of RADIO WORLD mailed to them after sending in their order, is automatic acknowledgment of their subscription order. Changes of address should be received at this office two weeks before date of publication. Always give old address also. State whether subscription is new or a renewal.

ADVERTISING RATES

General Advertising		
1 Page, 7 1/4"x11"	462 lines	\$300.00
1/2 Page, 7 1/4"x5 1/2"	221 lines	150.00
1/4 Page, 4 1/4"x D. C.	115 lines	75.00
1 Column, 2 1/4"x11"	154 lines	100.00
1 Inch		10.00
Per agate line		.75
Times Discounts		
52 consecutive issues		20%
26 times consecutively or E. O. W. one year		15%
4 consecutive issues		10%

WEEKLY, dated each Saturday, published Wednesday.
 Advertising forms close Tuesday, eleven days in advance of date of issue.

CLASSIFIED ADVERTISEMENTS

Ten cents per word. Minimum, 10 words. Cash with order. Business Opportunities, 50 cents a line; minimum, \$1.00.

Entered as second-class matter, March 28, 1922, at the Post Office at New York, New York, under the act of March 3, 1879.

MAY 30, 1925

Wanton Prophecy



ARTISTS will sit at a microphone soon and will broadcast actual cartoons, says Irving Hoofman, RADIO WORLD cartoonist. To prove it he drew this picture of himself actually demonstrating the feat!

Bernie Displaces Bonawitz In 1925 Popularity Contest In the Running



MAJ. J. ANDREW WHITE, WJZ special announcer, one of the contestants in the popularity contest.

WHEW! Ben Bernie and his Orchestra, WEAF, New York City, have leaped into the lead again in RADIO WORLD'S contest to determine whom its readers regards as the most popular radio entertainer of 1925. A few weeks ago Ben and his fellow uplifters occupied first place, by virtue of a small margin, but now—Ben and his crowd has more than twice as many votes as his nearest competitor, Karl Bonawitz, of WIP, Philadelphia.

That doesn't mean, however, that Bonawitz's friends and other admirers might not suddenly reduce their good feeling to voting form and displace Bernie and his co-workers. It may happen next week, Who knows?

The same speculative comment accompanied announcement of Bernie's previous lead, and true enough Bonawitz forged ahead, holding first place in the tally published last week. But then Ben's friends came right back at Bonawitz, with the result as it stood—temporarily, you know when this edition went to press.

The voting is becoming brisker, but there is still some indication of admirers of certain performers and announcers holding back their votes, as if to create a landslide toward the end. This is not good politics, we might say with absolute impartiality, and the outcome of Ben Bernie's early publicity clearly proves

Contest Rules

1. The votes in RADIO WORLD'S 1925 contest to determine the radio entertainer entitled to the popularity gold medal may be cast by filling out the coupon as published weekly in RADIO WORLD. One coupon entitles the sender to one vote. The coupon should be properly filled out and mailed. One subscribing to RADIO WORLD (a new subscriber or one renewing an existing subscription), may cast as many votes as are represented by the total number of weeks of the new or renewed subscription. In addition, as the coupons are published, the subscriber may use them for sending in one vote on each such coupon. When subscribing, cast your total subscription votes by specifying the candidate in the subscription order.

2. This contest closes July 31. The last coupon will be published in the July 25 issue.

3. In case of a tie, a gold medal will be awarded to each contestant so tied.

this. The attention of readers, obtained through these announcements and listings, brings forth votes even from unexpected quarters.

Right close behind Bonawitz is S. A. Rothafel, of the Capitol Theatre, New York City, who is dear to millions of radio hearts as Roxy. He is only three votes behind Bonawitz, and what's three votes between competitors?

The others for whom votes have been cast include Nils T. Granlund, announcer, WHN, New York City; Leo Reisman and orchestra, WBZ, Springfield, Mass.; Jack Little, Salem, Ill.; Alvin E. Hauser, WFBH, New York City; Gargle Wood, Harmony Hurricane, WAMD, St. Paul, Minn.; Hotel Commodore Orchestra, WJZ, New York City; Walter Peterson, WLS, Sears-Roebuck station, Chicago; Gold Dust Twins, WEA, N. Y. City; Ford and Glenn, WLS, and two new ones on the list, Lambdin Kay, announcer, WSB, Atlanta, Ga., and Doc Eisenbourg, WEEL, Boston, besides Major I. Andrew White.

Read the rules and cast your votes now.

RADIO WORLD'S POPULARITY TEST

To Determine the Gold Medal Radio Entertainer for 1925
 Popularity Editor, RADIO WORLD

I hereby cast one ballot for:

(Name of Entertainer).....

(Entertainer's Station).....

(Voter Sign Full Name Here).....

(Street and Number).....

(City)..... (State).....

No. 6-5-30.

FILL OUT THIS COUPON AND MAIL NOW!

Waves Travel Through Earth's Crust, Dr. Rogers Maintains

SUBLAND, subsea reception and transmission experiments are being conducted by Dr. James H. Rogers, at his research laboratory in Hyattsville, Md. With his aerial down a well, instead of up in the air, Dr. Rogers first succeeded in receiving from a short distance. Later the distance was increased, until finally he had heard concerts given in Europe, and picked up at the bottom of the well. The next problem was to broadcast, and this was successfully accomplished when stations in California, 3,000 miles away, received the code signals sent out from Hyattsville. A message from a station in Toulon, France, recently received by Dr. Rogers, verified that his subsea signals had been picked up there.

Ever since the first days of wireless the general belief has been that radio waves travel through the air, says the New York "Times." Thousands have built high towers and strung wires over housetops to capture these elusive waves.

The Ground Route Theory

Dr. Rogers's experiments evidently show that electric waves travel not only through the air, but through the surface of the earth—that they take the shortest and most direct route, or at least follow the path of least resistance in their flight; and some believe that, by stringing aerials in the air, listeners have handicapped themselves in developing radio.

Many times has Dr. Rogers, now 74 years old, been honored for his work in radio and his discoveries along electrical lines. He is an Honorary Fellow of the Maryland Academy of Sciences, and holds the inventor's medal of that organization. He holds numerous patents pertaining to electricity.

Numerous American submarines are equipped with the Rogers system of undersea radio, which makes possible their communication while submerged.

How Sending Is Done

The sending set which Dr. Rogers perfected and has been using in his experiments in subland and subsea broadcasting consists of four cables, each fifty feet long, laid in trenches and buried three feet underground. The cables are arranged in the manner of the spokes of a wheel, one pointing north, one south, one east and one west.

These cables are made of terra cotta piping eighteen inches in diameter. In their centre runs a copper tubing three-quarters of an inch thick, and packed in an insulation of glass. The messages are broadcast through this apparatus, the cable pointing in the direction Dr. Rogers wishes to send his message. By this method, he believes, a gain is made in directness and efficiency. In the transatlantic test an eastern cable was used.

Gets Verification

After this test, on April 11, Dr. Rogers received the following message from Toulon, France:

"Heard your station 3XR at Capitol 01 HOS GMT (1 A. M. Greenwich Meridian Time), about F8 meters calling CQ (any station which hears). Audibility QSA (very loud). Letter confirms.

(Signed) Sacazes M."

Thus far Dr. Rogers has made all of his tests in code. He has, however, made other tests for broadcasting the voice, and in every instance they have been suc-

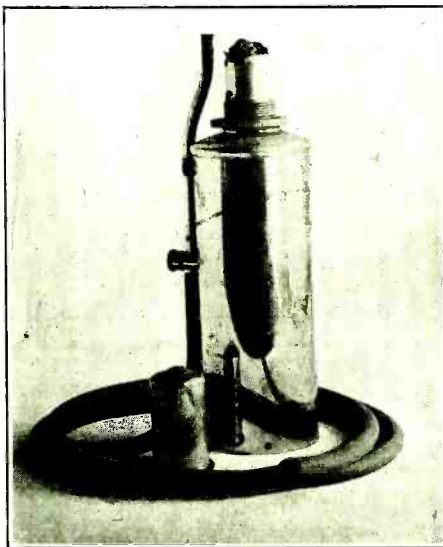

AIR ALCOHOL lamp serves nicely to beat a soldering iron, if you have no electricity.

cessful. Dr. Rogers conceived his theory of underground transmission in 1908.

Has His Own Theory

"The scientific world stated that Marconi would be enabled to send messages for only a very short distance," Dr. Rogers said. "This theory was held because it had been demonstrated by Hertz that electric waves obeyed all the laws of light and traveled always in a perfectly horizontal manner, not curving about the earth, but going off on a tangent.

"When Marconi received signals across the Atlantic, however, the scientists invented new theories to fit the case, all holding that radio waves went through the ether above. But I thought that Marconi's signals were not sent over such distances above the curvature of the earth. On the other hand, I thought that they traveled through the ground, through the medium of the crust of the earth. Thus I harmonized my theories with the older Hertzian theories."

It is Dr. Rogers's belief that the electric waves travel directly through the earth from the base plate of the broadcasting station to the base plate of the receiving station. They may, he believes, follow the course of least resistance.

Sun Cannot Absorb Waves

The revolutionary effect of these discoveries on radio is not always appreciated from the beginning. The first point to impress itself on the public is the elimination of static. Every radio enthusiast knows that broadcasting during the day is far less effective than at night. This, experts believe, is due to the short, or ultra-violet, rays of the sun, which exert their absorbing influence over the waves of electricity.

With the subland radio this condition is almost eliminated, Dr. Rogers points out. The ultra-violet rays cannot penetrate the land, and every station replying to code signals sent out underground by Dr. Rogers has reported reception loud and clear. At the same time the subland broadcasting will make possible, Dr. Rogers believes, the transmission of messages over far greater distances, and at a much reduced cost.

"The giant aerials maintained for transatlantic radio cost \$1,000,000," said Dr. Rogers. "The subland broadcasting sta-

Underground System Tried by U. S. as Aid In Mine Disasters

By Thomas Stevenson

WASHINGTON.

THE Bureau of Mines has been conducting intensive experiments in an effort to overcome obstacles in the way of underground radio reception and transmission. If the experiments are successful, rescue of entombed miners will be greatly expedited since relief activities may be directed from the inside.

Since the beginning of the tests many obstacles have arisen which seemed impossible to overcome. First, it was learned that in many localities underground, the radio signals could not be picked up, probably due to certain magnetic qualities connected with the mine.

Upon making that discovery, the Bureau of Mines centered its activities on line radio as a solution of the problem.

tion will cost but a few thousand dollars in comparison. The terra-cotta piping is the chief expense of the underground station, and it will not be liable to damage from wind storms and lightning."

Uses a 250-Watt Tube

Apart from the underground antennae the instruments used are about the same as the ordinary aerial transmitting instruments. One 250-watt tube is used, producing in the aerial four or five amperes of radiation, with a wave length of 170 meters. This is much less than the electric energy employed in the Government aerial transmitting stations, which use for trans-oceanic broadcasting wavelengths varying from 10,000 to 24,000 meters.

The development of the instruments for receiving and transmitting radio waves is about complete, Dr. Rogers believes. He has announced that he will soon undertake other experiments aimed at bringing out the full possibilities of operation with an extremely short wavelength.

In the meantime, the success of subland and subsea broadcasting has cleared up a point which has been troubling both scientists and radio enthusiasts for some time. It has been found that reception between certain cities was particularly difficult. Such a condition exists between Baltimore and Washington, and often it is almost impossible for a receiving station in Baltimore to receive a program broadcast from Washington.

Phenomena Explained?

Scientists now believe that the theory of radio waves traveling through the crust of the earth explains this phenomena. They point out that certain beds of peculiar soil, clay or iron deposits, may be responsible for this condition, as there certainly cannot be a permanent obstruction in the air.

His two assistants, Derrick S. Breitenbach and John H. Lunnaman, are in the laboratory much of the time. A great deal of time is spent in a specially constructed, metal inclosed, soundproof room,

MR. DX HOUND

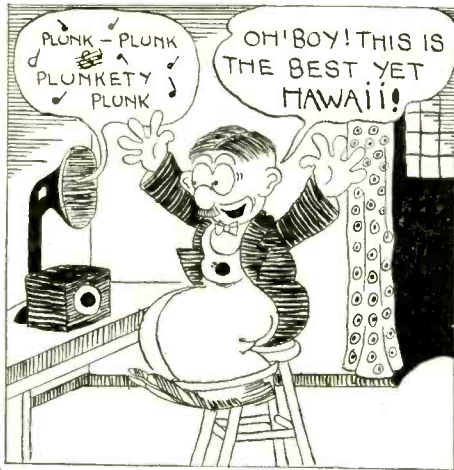

A Character Created by RADIO WORLD Artist

By HAL SINCLAIR



Literature Wanted

THE names of readers of RADIO WORLD who desire literature from radio jobbers and dealers are published in RADIO WORLD on request of the reader. The blank below may be used, or a post card or letter will do instead.

Trade Service Editor,
Radio World,
1493 Broadway, New York City.
I desire to receive radio literature.

Name

City or town.....

State

Are you a dealer?.....

If not who is your dealer?.....

His Name

His Address

- A. A. Meyers, 162 Breckinridge, Buffalo, N. Y.
 - Danzers Radio Shop, Pt. Townsend, Wis.
 - L. L. Berason, 44 Ella St., Portland, Ore.
 - Stewart Lamb, 774 E. 19th St., No. Portland, Ore.
 - Dr. F. McFadden, Starret Building, Athol, Mass.
 - H. E. Miller, 515 West 185th St., N. Y. C.
 - Elmer Jenson, Box 156, Issaquah, Wash.
 - Guy Lawrence, Miami, Ind.
 - R. Backes, 210 Clarke St., Milwaukee, Wis.
 - J. J. Trainor, Station B, Box 94, Brooklyn, N. Y.
 - C. D. Williams, Box 264, Greensboro, N. C.
 - Louis Perisky, 120 Fairfield Ave., Bridgeport, Conn.
 - Rodney Brown, 630 East 8th St., Portland, Ore.
 - Midwest Phonograph Exchange, Chadron, Neb.
 - Wm. M. Thalhimer, 600 Keith & Perry Building, Kansas City, Mo.
- heart of automotive section. Act quickly if you feel you are a man who can do a big business. Box 3, Radio World.

**Business Opportunities
Radio and Electrical**

Rates: 50c a line; Minimum, \$1.00

SALESMAN, CAPABLE, ENERGETIC, experienced department store trade, desires to represent in Philadelphia responsible concern with meritorious and profitable merchandise. Address B. F. S., 702 President St., Brooklyn, N. Y.

NEW STYLE WOOD RADIO LOUD SPEAKER; splendid opportunity for firm or individual to finance manufacturing and manage sales; owner possesses broad experience in woodwork; brokers and promoters ignored. Box 1, Radio World.

WANTED—Automotive or Radio Product. Established manufacturer with large factory and sales organization and successful experience in manufacturing and marketing automotive and other metal products is open to add article of proven merit to his line; please give full particulars. Box 2, Radio World

RADIO AND MUSICAL INSTRUMENTS, Sporting Goods, Leather Goods, Luggage. Extraordinary opportunity afforded a thoroughly experienced responsible man to rent sufficient space for any of the above lines in the largest auto supply store on Broadway, established 1907, same block 18 years. Rent very reasonable including light, heat, window, delivery and porter service, plus a desirable accessible location. In

THE RADIO TRADE

**Victor to Market a Combination
Radio Set and Phonograph**

Great Stars, Under Exclusive Contract with Victor, Will Broadcast.

THE VICTOR TALKING MACHINE CO. announced at a dinner at the Hotel Pennsylvania, New York City, that it will market a combined radio-phonograph instrument. The receiver will

be the Radio Corporation's Super-Heterodyne. J. G. Paine, counsel for Victor, made the speech announcing the plan.

Another important statement by Mr. Paine was that the Victor Co. will resume broadcasting. Plans have not been perfected, but it is promised that great artists will be on the air. Under this arrangement these great concert and opera singers, as well as instrumentalists, will be paid. In the tests last Winter, John McCormack, Lucrezia Bori and the other big lights in music were not paid.

**Freshmen Cuts Out Jobbers
and Distributors for 1925**

THE Chas. Freshman Co., Inc., of New York, announced their sales policy for the coming season. This concern, manufacturers of the line of Freshman Masterpiece Receiving Sets, has decided to eliminate the jobber and distributor in the sale of their products. Freshman Masterpiece Sets will be sold to authorized Freshman dealers, carefully selected, and granted an exclusive franchise in their territory. In towns of approximately 25,000 and under, one representative dealer will be appointed to handle exclusively the whole line, and in larger cities, additional dealers will be granted franchises in proportion to the population and trading area.

A staff of salesmen is now at work signing up dealers to the Freshman Masterpiece contract, which assures dealers of protection, as far as stability of prices is concerned; also, all business from each individual dealer's territory will be credited to him. In this way, the appointed dealers will be practically direct factory representatives of the Freshman Company.

The Freshman Company enjoyed remarkable success with their one model, the original Freshman Masterpiece, during the last year. The

model, priced at \$60 was sold to the extent of over 125,000 sets from July, 1924, until February, 1925.

With the realization that the trend in radio buying is leaning strongly towards furniture effects, the company has placed a complete line of Freshman Masterpiece Receivers on the market, ranging in price from a 5-Tube Audio-frequency set, in a massive cabinet with sloping panel at \$39.50, up to the Franklin Console, a dignified piece of furniture of vigorous lines and fine proportions, made entirely of genuine solid mahogany, at \$115. The Franklin Console is composed of two separate and distinct units, one of which is a receiving set with built-in speaker, and the other the console for batteries and accessories, everything being concealed.

Among the other models which will shortly be sold through Freshman authorized dealers is the concert model, listing at \$75. This model embodies a speaker.

Dealers will be supported by a tremendous advertising campaign—including advertising in their home town papers over their names and addresses.

HARBORD DENIES LIQUIDATION OF G. E. HOLDINGS

GENERAL JAMES G. HARBORD, President of the Radio Corporation of America, who sailed for a five weeks' trip to Europe, said there was no truth in reports that the General Electric, the Westinghouse or United Fruit had liquidated any of their holdings in the Radio Corporation.

"The corporation is in a good financial position," he added, "and making money. I expect earnings to run ahead of last year. It is true there has been a seasonal slump in radio, due to some cheap outfits which have flooded the market, but the absorption point of the radio industry is far distant. There are no radical changes contemplated in radio construction and people possessing sets will be able to use them for sometime to come."

THE BABY PORTABLE, by Herbert E. Hayden. A 1-tube DX set on a 7 1/2 x 5 1/2" panel. Send 30c for May 16 and 23 issues to RADIO WORLD, 1493 Broadway, New York City.

NEW INCORPORATIONS

Prairie State Radio Co., 39 W. Adams St., Chicago, Ill., capital, \$120,000; 1,000 shares, no par value. Manufacturing and dealing in radio sets, cabinets and radio devices. Incorporators: W. J. Walsh, F. E. Walsh, and K. B. Walsh. Correspondent: R. L. McVean, 10 S. La Salle Street, Chicago, Ill.

Western New York Radio Service, Buffalo, N. Y., \$5,000; W. C. Kruse, Jr., A. J. Graham, B. Howe. (Atty., E. F. Kruse, Buffalo, N. Y.)

General Winding Co., radio coils, (N. Y. C.), \$10,000; C. and E. and B. Spiegler. (Atty., H. Messard, 227 Broadway, N. Y. C.)

Larchmont Radio Corp., Larchmont, N. Y., \$3,000; A. S. Fogelstrom, A. C. Boyan. (Atty., H. M. Scobel, New Rochelle, N. Y.)

Northland Radio Co., Delaware, \$3,000,000; W. R. Frank, Hans F. Aude, F. Olien Peters, Minneapolis, Minn. (Corporation Trust of America.)

Compania Stromberg Carlson de Telegnos y Radio, Wilmington, Del., deal in cables, \$10,000. (Corporation Trust of America.)

WHAT ARE HARMONICS?

MISS GRACE HAGEN, assistant physicist, Bureau of Standards, discussing harmonics, said:

"Harmonics are exact multiples of the fundamental frequency generated. To make use of these harmonics the two radio-frequency generating sets are adjusted by means of zero beat. The wavemeter is tuned to resonance with the second radio-frequency generating set and a condenser setting of the wavemeter read for each wavelength measured on the wires and its harmonics.

"To establish the kilocycle directly the Bureau of Standards uses a tuning fork as a basic standard. Its frequency is first accurately determined by comparison with the fundamental standard of time. The tuning fork is placed in an electron tube circuit so that its frequency controls the frequency of the electrical output. Thus a tuning fork of 1000 cycles per second, which is approximately twice as high a frequency or pitch as middle C, will give an electric output of the same frequency, 1000 cycles per second. This is equal to a kilocycle which is equivalent to a wavelength of 300,000 meters.

"The radio laboratory is now using a harmonic amplifier to step the tuning-fork frequency up to radio frequencies. This amplifier increases the current strength and distorts the wave form so that more harmonics are produced than

would naturally be present in the tuning fork output. The amplifier is tuned to some harmonic of the 1000-cycle tuning fork, for example the 10th. This frequency of 10 kilocycles is in the radio range and a reading is taken on the wavemeter corresponding to this value. The next harmonic is then tuned in and the 11 kilocycle point determined on the wavemeter condenser scale. This process is followed for a series of harmonics. To reach considerably higher frequencies it is necessary to use some frequency higher than 1 kilocycle to give greater spacing between points on the condenser dial. A second amplifier of two stages is coupled to it and by tuning to some harmonic this serves as a trap shutting out the other frequencies and gives a new source of harmonics, say 10 kilocycles apart. By this means the range covered is extended to the 400th harmonic.

Recording Harmonic Frequency

"The frequency of each harmonic is recorded with the corresponding wavemeter settings. An additional amplifier is used for still higher frequencies which is tuned to give still greater frequency intervals. With this apparatus the range is further extended to 4000 kilocycles. Thus the frequency values, obtained from a known audio source covering a range of 10 to 4000 kilocycles, are incorporated in the standard wavemeter.

"The Bureau of Standards has used several other methods in comparing a fundamental frequency with the wavemeters as well as those just described. The wavemeters thus standardized are called primary standards. They give the basis for all comparison work, such as determining the frequency of broadcast stations which are announced as standard frequency stations."

Their Summer "Vacation"

IT is probable that when the next conference meets Secretary Hoover already will have formulated a legislative program which will be placed before the body for consideration. During the summer some of the best minds of the Department of Commerce, in company with Representative White, will give this problem consideration with the view of making recommendations to Secretary Hoover.

Considerable study will also be given to the subject of interconnection of stations. This matter was taken up by the last conference and a standing committee appointed to make an investigation. Developments during the past year will probably be reviewed and recommendations forthcoming for future procedure.

MARCH EXPORTS \$604,769 WASHINGTON.

RADIO exports during March totaled \$604,769. Principal countries which purchased American radio equipment during that month were Netherlands \$14,460; Russia in Europe \$14,282; Spain \$41,982; United Kingdom \$35,948; Canada \$119,767; Mexico \$21,941; Argentina \$62,315; Brazil \$19,571; Philippine Islands \$17,950 and Australia \$64,230.

STATIC REDUCED TO A MINIMUM REDUCED BATTERY CONSUMPTION



Welty's DeLux Crystector

Welty's Crystector fits in standard tube socket instead of detector tube in neutrodyne and radio frequency sets. No trouble to install. Wiring not changed—distance and volume only slightly reduced. The difference in natural tone and lack of static is wonderful. Summer reception is a pleasure as compared with tube detector.

LET US PROVE IT

If the Crystector does not function in your set, money cheerfully refunded.

Price, \$4.00 Prepaid

WM. A. WELTY & COMPANY
36 S. STATE STREET, CHICAGO, ILL.

Baseball Season is Here! Cash In
Now is the time to take advantage of our special bargain prices.
Lightning Arresters, Insulators, Freshman Kits, Head Sets, Tubes, Complete Sets.
MR. DEALER, WRITE NOW FOR OUR LIST
Baseball Season is pretty near, GET READY.
THE BOWER RADIO SHOP
Wholesale Radio Reading, Michigan

THE GENUINE LOUDSPEAKER
\$1.50 Vacuum Tubes \$1.50
C. O. D., JUST PAY POSTMAN
MONEY BACK GUARANTEE
JAMES H. KONKLE
192 Market Street Newark, N. J.

WRITE FOR NEW CATALOGUE
Home of Semi-Assembled Kits
THE RADIO SHACK
55 Vesey Street Dept. E-155 New York



"A THING OF BEAUTY AND A JOY FOREVER."

TYPE 5A 5-TUBE \$50

American Interstate Radio
183 Greenwich St., N. Y. C.

SILVER Dealers!

Send for our new illustrated dealer's catalog with latest wholesale and retail radio bargains. Also ask for our attractive proposition to radio dealers on nationally advertised lines.

Silver-Marshall, Inc.
112 S. Wabash Avenue, Chicago

MARSHALL

GLOBE Low - Loss Tuners

Best for all speakers because they lose nothing

Globe Radio Equipment Co.
217 West 125th Street New York

KESTER Radio SOLDER (Rosin-Core)

If your dealer cannot supply you send us 25c in postage

CHICAGO SOLDER COMPANY
CHICAGO, U. S. A.

Get the BIG PAY RADIO Job

I'LL SHOW YOU HOW
There are thousands more big pay fascinating radio positions open than there are men to fill them. I know what and where these real positions are—and I can qualify you, in a few weeks spare time, to fill one of these positions so you can earn \$3,000 to \$10,000 a Year—Learn I have successfully trained thousands of men in Home Electricity, Wireless and Radio for 15 years. I can make you a full-fledged radio expert quickly; a titled, big pay man. You will learn how to install and maintain transmitting and receiving apparatus, professional and amateur, land and sea. You will know Radio thoroughly—and will get the biggest money because of your better, broader training. Send name and address for Big Set Free! a full outline of my course and how to get the big A. R. E. Twin Superdon Experimental Set absolutely FREE. Write me personally! Irwin J. Mendel's
AMERICAN RADIO ENGINEERS
646 N. Michigan Ave., Dept. 85 Chicago

Get My Book Free

The Five Tube Set which startled the World!

FRESHMAN MASTERPIECE

Line of new and improved tuned radio frequency receivers.

For sale by authorized Freshman dealers only.

THE BLUEBIRD REFLEX 2-tube earphone marvel by Capt. Peter V. O'Rourke. Send 15c for February 7 issue. RADIO WORLD, 1493 Broadway, New York City.

A SET FOR REDUCING STATIC, with diagrams, in RADIO WORLD dated May 9. 15c per copy, or start your subscription with that number. RADIO WORLD, 1493 Broadway, N. Y. C.

HOW TO BUILD A NEUTRALIZED LOOP, by Frank Freer. Send 15c for May 2 issue, RADIO WORLD.

Subscribers desiring to change their addresses should send in such changes at least two weeks in advance, because Radio World's subscription list is so large that this length of time is required for changes.

Subscription Manager, Radio World, 1493 Broadway, New York City.

Men Are DX Hounds, Says Mack; Hear Call Letters, Not Programs

By Percy W. Mack

Vice-President, Acme Apparatus Company

THE hand that rocks the cradle and rules the world will have an important part in shaping the destinies of radio. Women are becoming an increasingly important factor in the development of the new utility. Although women spend 85 per cent. of the money that goes into the home, they have not been sold on radio as rapidly as might have been expected with a utility which is so essentially for use in the home.

This has been due largely to the fact that radio has been enshrouded in technicalities.

The man is likely to monopolize the set in the home, and in his eagerness to get distance he rarely keeps the same program on for more than a few minutes. He might not admit it, but what he is really hearing is call letters, not programs.

The woman, on the other hand, realizes that the real and lasting thrill in radio is not distance, but quality. She knows that the distance obsession is diminishing. To a woman radio is essentially a musical instrument, and just as women are generally more

religious than men, they are better listeners to good music. Naturally they wish their radio set to look as well as any other musical instrument and be as suitable for the living room or parlor. They do not want a conglomeration of wires, batteries and electrical apparatus, but a good looking, compact, self-contained receiving set which looks like what it is—a musical instrument. In the end woman will get what she wants and there is a distinct trend in the radio industry toward recognizing that her viewpoint must be met, and that the most substantial results in increasing the number of American homes having receiving sets will come about through women developing an interest in the utility.

Many people have asked the question why there are as yet only 3,000,000 homes in which there are radio sets instead of 16,000,000 or 17,000,000 compared with the automobile and telephone.

The Three Curses of Radio POWER NOISES, STATIC, RERADIATING SQUEALS

The Kane Antennae absolutely eliminates all power noises.

The Kane Antennae cuts real "static" and re-radiating squeals at least in two.

The Kane Antennae enables you to get the full benefit of your Receiving Set *All Summer Long.*

Another of our many satisfied customers proves our claims in the following letters.

"HE SUFFERED GRIEF AND PAIN"

April 14, 1925.

Gentlemen:—Referring to your Ad. in "Radio World" in regard to your Antennae, I have a six tube Super Zenith operating on wet "A" battery, and am troubled with power noises and static, being located within 75 yards of a 50,000 volt power line. Located in two story building and have set on second floor. Depot is between two railroad tracks.

Kindly advise if you think your Antennae would help me out under the above circumstances. Kindly give dimensions of Antennae, that is, length and distance from ground lowest wires would be. It is almost imperative for me to run Antennae across railroad track.

Hoping to hear from you soon,
Yours truly,
(Signed) B. H. BEAVER,
Agent, ATSF RR Co.,
Johannesburg, Calif.

"THEM DAYS IS GONE FOREVER"

May 6, 1925.

Gentlemen:—

I have installed one of your Antennae which you recently shipped me, and find that it has eliminated all power induction from 50,000 volt power line within 150 feet of Antennae's location.

Several stations that I could not bring in at all on account of this power induction I now bring in clearly. Needless to say it has improved greatly reception from all stations.

Thanking you for promptness in filling order and wishing you success,
I am

Yours truly,
(Signed) B. H. BEAVER,
Agent, ATSF RR Co.,
Johannesburg, Calif.

SEE FOR YOURSELF WHAT THIS WONDERFUL ANTENNAE IS

We will sell you working drawings with instructions for erecting this wonderful Antennae for a dollar bill. If after looking over the drawings you decide you would rather have a factory-built Antennae than build one yourself, we will take back the drawing and allow you full purchase price on an order for an Antennae.

- The Special Kane Antennae for Radiola Super-Hets..... \$6.50
- The Regular Kane Antennae for all other sets that use a ground connection.....\$13.00
- Working Drawings with Instructions for Erecting..... \$1.00
(Stamps Not Accepted)

Postpaid to any part of the United States, or sent C. O. D. when 25 per cent of price accompanies order.

"Hear As You Have Never Heard Before"

THE KANE ANTENNAE COMPANY
Dept. W, ABERDEEN, WASHINGTON

Tested and approved by Radio World "TRI-TUNER"



Build Your Own Set!
Use Arc Rad Products.
A Three-Circuit Coil, all Litz wound on natural bakelite.
SENT POSTPAID \$3.00
Panel shield and hook-ups included. Fahnestock clips used.

Eliminate Soldering
ARC RAD PRODUCTS
48 South 7th Street Newark, N. J.
EVERY PRODUCT GUARANTEED

"HOW TO MAKE—"

The following constructional articles have appeared in recent issues of RADIO WORLD:

- Sept. 6—1924—A simplified Neutrodyne with Grid-Biased Detector, by J. E. Anderson.
- A Low-Loss Wave Trap, by Brewster Lee.
- Nov. 15—A Sturdy Low-Loss Coil, by Lieut. P. V. O'Rourke. An Ultra 2-Tube Receiver, by Byrt C. Caldwell.
- Dec. 6—A 6-Tube Super-Heterodyne Using a Variometer, by J. E. Anderson. A \$1 Coil Winder, by Herbert E. Hayden.
- Dec. 13—The World's Simplest Tube Set, by Lieut. P. V. O'Rourke.
- Dec. 20—A 1-Tube DX Wonder, Rich in Tone, by Herman Bernard. An Interchangeable Detector, by Chas. M. White.
- Dec. 27—A 2-Tube Variometer Set, by Lieut. P. V. O'Rourke.
- Jan. 3, 1925—A 3-Tube Portable That Needs No Outdoor Aerial, by Abner J. Gelula.
- Jan. 10—A Low-Loss DX Inductance, by Herbert E. Hayden.
- Jan. 17—A \$25 1-Tube DX Wonder, by Abner J. Gelula.
- Jan. 24—A Selective \$15 Crystal Set, by Brewster Lee. A Variometer-Tuned Reflex, by Abner J. Gelula. An \$18 1-Tube DX Circuit for the Beginner, by Feodor Rofpatkin.
- Jan. 31—A Transcontinental 2-Tube Set, by H. E. Wright. An Experimental Reflex, by Lieut. P. V. O'Rourke.
- Feb. 7—The Bluebird Reflex, by Lieut. P. V. O'Rourke. A \$5 Home-Made Loudspeaker, by Herbert E. Hayden.
- Feb. 14—A Super-Sensitive Receiver, by Chas. H. M. White. A Honeycomb RFT for DX, by Herbert E. Hayden.
- Feb. 21—A 1-Tube Reflex for the Novice, by Feodor Rofpatkin. A Set for Professional Folk, by Lieut. P. V. O'Rourke. A Honeycomb Crystal Receiver, by Raymond B. Wallis.
- Feb. 28—A Set That Does the Most Possible With 6 Tubes, by Thomas W. Benson. Three Resistance Stages of AF on the 3-Circuit Tuner, by Albert Edwin Sonn.
- March 7—Storage B Battery, by Herbert E. Hayden. Benson's Super-Heterodyne.
- March 14—The Reflexed 3-Circuit Tuner That You Can Log, by Herman Bernard.
- March 21—A Variable Leak, by Herbert E. Hayden. A 4-Tube, 3-Control Set That Gets the Most DX, by Lieut. P. V. O'Rourke.
- March 28—The Improved DX Dandy Set, by Herbert E. Hayden. A 3-Tube Reflex for the Novice, by Feodor Rofpatkin.
- April 4—The Diamond of the Air, by Herman Bernard. What the New Sodorl Tube Is, by Sidney E. Finkelstein. Sets for the DX Devotee, by Lieut. P. V. O'Rourke.
- April 11—Audio Hookups for Fine Volume and Quality as Well, by Brewster Lee. The Coils for The Diamond, by Herman Bernard. 1-Tube Distance-Getting Sets, by Lieut. P. V. O'Rourke.
- May 2—The Twinplex, by J. E. Anderson.
- May 9—A Set to Cut Static, by Feodor Rofpatkin. Toroid Circuit with Resistance AF, by E. I. Sidney. A Push-Pull AF Amplifier, by Lt. Peter V. O'Rourke.
- May 16—A 3-Tube Reflexed Neutrodyne, by Percy Warren. The Baby Portable, by Herbert E. Hayden. One Tube More for Quality, by Brewster Lee.
- May 23—Powerful 3-Tube Reflex Receiver, by H. E. Wright. The 3-Control Diamond, by Herman Bernard.

Any copy, 15c., Any 7 copies, \$1.00. The whole 25 copies for \$2.80, or start subscription with any issue. Radio World, 1493 Broadway, N. Y. City.

Ingenious Artist



MISS DAISY JEAN, Belgian cellist and harpist, rehearses a number on the harp for the American Women's Association Radio Revel at the Hotel Plaza, New York City. This was broadcast through WBOQ, one of the two A. H. Grebe stations at Richmond Hill, N. Y. (International Newsreel.)



Sterling Five

Highest quality five tube tuned radio frequency set in solid mahogany cabinet. List Price.

\$60.00

Write for free Log Book. Gibson-Sears Radio Corp. 48 W. Broadway, New York

ACME POWR-BEE

Better Than "B" Battery

NO HUM NO NOISE

Reduces the cost of radio. At your dealer's or write.

THE ACME ENGINEERING CO.

Dept. 3 LOUISVILLE, KY.

Dealers write for big sales proposition.

JOIN THE A. B. C.

A B. C. stands for the American Broadcast Club. Join it today. It involves no dues or payment of any kind, and no obligations. It was founded by RADIO WORLD simply to unite the broadcast listeners and radio fans in general in a common bond to promote their welfare as occasion requires. Send your name and address to A. B. C. Editor, RADIO WORLD, 1493 Broadway, New York City.

Francis M. F. Field, Quarters No. 25, Governors Island, N. Y.
C. D. Williams, P. O. Box 264, Greensboro, N.C.
W. B. Hermann, 1818 Avenue L, Brooklyn, N.Y.

FREE BOOKLET FOR INVENTORS

IF YOUR INVENTION is new and useful it is patentable. Send me your sketch. Z. H. POLACHEK, 70 Wall St., New York.
Reg. Patent Attorney-Engineer

RADIO FANS—

Each station's dial settings at a glance. But only one at a time. No eye strain—no confusion—compact—practical.

Send 10c in coin or stamps for our Radio Station Recorder.

E. R. Products Co.
133 Lehigh Ave., Newark, N. J.

A. B. C. Editor, RADIO WORLD, 1493 Broadway, New York City.

Please enroll me as a member of the American Broadcast Club.

Name

Address

City or Town

State

THE ASTON CARD INDEX

RECORD YOUR RADIO STATIONS

Copyright 1924 by S. T. Aston & Son

Telephone Franklin 2159



\$3.00

Complete Postpaid

100 Cards, Mahogany Finish or Oak Cabinet, and Index Dividers. A Useful Accessory to Any Set. Give Name of Set and Sketch of Dial Arrangement. Postpaid on Receipt of Cash or Money Order. Dealers Write for Terms.

S. T. ASTON & SON

114 WORTH STREET NEW YORK CITY

THE BABY PORTABLE, by Herbert E. Hayden. A 1-tube DX set on a 7½x5¼" panel. Send 30c for May 16 and 23 issues to RADIO WORLD, 1493 Broadway, New York City.

SUMMER SPECIALS

- Roberts 4-Tube Knockout Kit \$42.50
 - Well-known 5-Tube T. R. F. Set..... 29.50
 - Hammerlund .0005 Condensers..... 4.00
 - Acme D. Coils..... 9.75
 - Ekko Stamp Albums..... 0.95
 - Brach Soldering Irons..... 1.65
 - Crosley Musicone Loud Speaker..... 13.95
 - Jewett Superspeaker..... 21.95
 - Little Gem Head Set..... 2.50
- Send for our free summer special folder on sets and parts. Real bargains on standard parts and sets. Your opportunity to save money.

LIBERTY MAIL ORDER HOUSE

Dept. S-100

106 LIBERTY STREET, NEW YORK, N. Y.

HOLLAND TUBES



Are Setting the Radio Nation Afire With Enthusiasm **INTRODUCTORY PRICE FULLY GUARANTEED \$1.75 EACH**

A matchless 6 Volt 25 Amp. Tube, faultless as detector and amplifier.

Thousands of fans say they have never heard their equal. Make the tubes prove it!

MAIL ORDERS FILLED

Genuine Imported Tubes, Made in Holland

Sole Distributors:

TERMINAL

CYCLE & SPORTING GOODS CO.

42 CORTLANDT ST., NEW YORK

TELEPHONE, CORTLANDT 4890

General Sporting Goods

Out Next Week!

RADIO WORLD'S Fourth Annual Vacation Number Dated June 6, 1925

LAST COLOR FORM CLOSSES MAY 25

LAST BLACK FORM CLOSSES MAY 26

REGULAR ADVERTISING RATES IN FORCE

Address Advertising Manager, RADIO WORLD, 1493 Broadway, New York City

The 1-Control Neutrodyne

(Concluded from page 6)

A minus on the strip. Connect both the A minus and the ground together. The plate of this tube socket goes to the end of L3. The left off connection of the neutralization condenser goes to the 12-turn tap on the secondary of the second RFT (L4). The top of L4 G goes to grid of the socket second from left and also to one end of the other neutralization condenser, the other side of N going to the 12th-turn tap of the third RFT, L6. The end of L4 goes to the A minus and also to the rotary plates of the double condenser and to the end of the third RFT, L6. The beginning of the primary winding, L5, goes to B+, the end of L5 to preceding plate. B plus is also connected to the beginning of L3. The beginning of L4 and L6 go respectively

to the stationary plates of the variable condenser. The variable gridleak (Bretwood) goes to F plus. The rheostat of the detector tube is placed in the negative lead of the A battery. The two steps of audio-frequency amplification are added in the regular fashion. All the amperites are placed in the negative lead of the A battery. R3 is placed across the secondary of the first audio-frequency transformer and is a 100,000 ohms resistor. The F minus of the C battery goes to the F posts of the two AFT, the plus post of this C battery going to A minus. S2 is placed in the A plus lead, and S1 is placed in the filament plus of the other three tubes.

How to Neutralize the Set

After you have finished the wiring, tip the coils at a 57.3 angle. Tip the coils until there is no more an oscillatory action in the tube. Tighten or loosen the screws on N, until the signals are received smoothly on the phones. Many more difficult explanations have been given, but the above directions, carefully followed, will do nicely.

Somewhat higher capacity neutralizing condenser is necessary in this circuit than in most others, due to the inclusion of the double condenser, whose electrostatic fields adjoin. Therefore the usual sleeve type of neutralizing condenser will hardly do. As trouble is most likely to be experienced on the lower waves, say below 450 meters, it is well to do the neutralizing when a loud local is tuned in on a wave lower than that. Above 450 meters no oscillation is to be expected and were stations operated on or above that wavelength there would be no need of the Neutrodyne.

How to Tune the Set

Light filaments of the tubes by pulling the switch and turn the dial until you hear a station. If the set still oscillates, tip the coils still more and tighten the screws on the vario-denser. You will always get your stations on the same spot, unless you have a leaky antenna, which will naturally broaden the tuning.

How to Get the Best Results

Use a short antenna (about 80 foot), the ground connection being very short and made to the cold water pipe. Use No. 18 DCC wire throughout in wiring the set. Do not bend the wire at sharp corners, because the radio-frequency currents will go off through the ends and energy will be lost.

If there is distortion, increase the leak resistance.

GETTING EFFICIENCY

(Concluded from page 11)

lightning arrestors, in the rheostats, etc., etc.

5—What type of inductance does a coil represent and how is it distinguished from any other inductance?

Concentrated inductance appears in the coil and distributed inductance appears in the condenser or in the internal part of the tube, etc.

6—What is the best method to install a ground?

See Fig. 3.

7—What is meant by screening an antenna?

See Fig. 4.

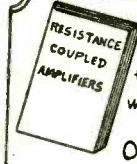

RESISTANCE COUPLED AMPLIFIERS
A new booklet that tells how to obtain wonderful tone with your present set at very low cost.
Only 10 Cents Postpaid
COLE RADIO MFG. CORP. BLOOMFIELD, N.J.



Famous for Quality and Service
Amplitron Tubes
Bonded to Give Service \$3
List Price.....
Send in your old and burnt out Tubes—We will send you new AMPLITRON—any model—at..... \$2.50
Dealers and Jobbers—Write for Discounts
Pennant Radio Laboratories
Dept. R.W., 28 Central Ave., Newark, N. J.

SPECIAL! Timmon's B-Lim... \$16.00
Sodion Tubes..... 3.75
Write me your RADIO wants. Lowest Prices. Immediate Delivery.
All "Bruno" Parts and standard merchandise in stock.

GEORGE'S RADIO SHOP
214 ST. NICHOLAS AVE. N. Y. CITY

S-U-P-E-R-D-Y-N-E

SPECIALISTS

The Famous Wallace Low-Loss Coil for Superdyne, \$7.50
The Flowing Condenser for Superdyne..... \$9.00
Superdyne Advice Free. Mail Orders Solicited.
WALLACE RADIO COMPANY, Inc.
135 LIBERTY STREET NEW YORK CITY

ACME

for amplification

GEM TUBE

A Guaranteed Radio Tube Within Reach of All

Every tube guaranteed. A tube for a dollar of \$3 value. A trial order will convince you as it has thousands of others. Send your order at once. Orders sent C.O.D. parcel post.

Type...201A
Type...200
Type...100
Type...100A
\$1.00 EACH

(with standard base)
Dealers, Write for Discounts
GEM TUBE CO.
Dept. W, 200 Broadway
New York City



THE BABY PORTABLE, by Herbert E. Hayden. A 1-tube DX set on a 7 1/2 x 5 1/2" panel. Send 30c for May 16 and 23 issues to RADIO WORLD, 1493 Broadway, New York City.

A POWERFUL 3-TUBE REFLEX, by H. E. Wright. Send 15c for May 23 issue, RADIO WORLD.

PANELS

RADION and HARD RUBBER
RETAIL ANY SIZE WHOLESALE
PRICE LIST MAILED ON REQUEST

HARD RUBBER SHEETS—RODS—TUBING

Special Hard Rubber Parts Made to Order. Send Sample or Sketch for Quotation.

NEW YORK HARD RUBBER TURNING CO.
212 CENTRE ST. NEW YORK

FAHNESTOCK CLIPS

"Popular Wherever Radio Is Used"

14 Sizes in Beautiful Display Case
Dealers, write for big money-making proposition.

FAHNESTOCK ELECTRIC CO.
Long Island City, L. I.



Over 130 standard radio parts, each bearing the Federal iron-clad performance guarantee.

Write for Catalog

Federal Telephone & Telegraph Co.
Buffalo, N. Y.

KITS

Before you buy that Kit, write for our prices. We will save you money.

\$17.50 Freshman R. F. Kit.....\$9.50
A Limited Number at This Price—Order Now
All Standard Kits in Stock

George C. Sprouls 5739 N. Sixth St.
Philadelphia, Pa.

PANELS

FOR PRESSLEY, SUPERDYNE, "DIAMOND OF THE AIR," ETC. CUT, DRILLED AND ENGRAVED

Cortlandt Panel Engraving Co.
81 Cortlandt Street New York City

\$100—\$500 Weekly

can be made by operating a branch radio factory. Can be started in your own home.

We furnish complete outfits and establish you in business. Knowledge of radio helpful, but not necessary, as we teach you.

This revolutionary five tube set retails for \$35.00 and equals sets selling at \$100 to \$200.

It Works on Inside or Outdoor Aerial or on a few feet of Talking Tape thrown on floor.

Free sample if you qualify. Write or wire, naming your county for exclusive proposition.

ROYAL MFG. COMPANY

Dept. W 206 Broadway, New York

THE KEY TO THE AIR

(Concluded from page 19)

6:30 A. M. to 7:30; 10:55 to 1 P. M.; 2:25 to 2:30; 6:02 to 11.

CNRC, Calgary, Canada, 430 (M. S. T.)—7 P. M. to 10.

CNRM, Montreal, Canada, 411 (E. S. T.)—8:30 P. M. to 10:30.

CNRW, Winnipeg, Canada, 384.4 (C. S. T.)—8 P. M. to 10.

KDKA, Pittsburgh, Pa., 309 (E. S. T.)—9:45 A. M. to 10:30; 11:55 to 12 M.; 2:30 P. M. to 5:30; 7 to 11.

S. HAMMER RADIO CO.

303 Atkins Avenue, Brooklyn, N. Y.
Please send me FREE, Your NEW RADIO CATALOG

Name
Address
City State

FILL OUT AND MAIL

GETTING BETTER QUALITY FROM AUDIO, by Brewster Lee. Last AF stage connected to two tubes in parallel. Send 15c for May 16 issue to RADIO WORLD, 1493 Broadway, New York City.

Increased Power Made Easier in Drive on Static

By Thomas Stevenson
WASHINGTON.

CLASS B stations located outside of cities will be permitted to use maximum power during the coming summer months. No experimenting by increases

For Maximum Amplification Without Distortion and Tube Noises use the well known
Como Duplex Transformers
Push-Pull
Send for Literature
COMO APPARATUS COMPANY
448 Tremont Street Boston, Mass.

HERCULES AERIAL MAST

20 Ft. Mast \$10
40 Ft. Mast \$25
60 Ft. Mast \$45

All steel construction, complete with guy wires and masthead pulley. We pay the freight.
S. W. HULL & CO., Dept. E3
2048 E. 79th St., Cleveland, O.

Write for literature and **FREE** Blueprint

CROSLEY

RADIO CATALOG FREE
Describes fully the complete line of radio frequency sets, regenerative sets (licensed under Armstrong U. S. Patent No. 1,113,148) and parts.
Write for Catalog Today.
THE CROSLEY RADIO CORPORATION
POWEL CROSLEY, Jr., President
5404 Sassafras Street Cincinnati, Ohio

ULTRA-VERNIER TUNING CONTROL

A VERNIER DIAL ON WHICH YOU CAN PENCIL RECORD THE STATIONS. GEARED 20 TO 1. SILVER FINISH \$2.50—GOLD FINISH \$3.50

PHENIX RADIO CORP., 116-F East 25 St., N.Y.C.

BABY PORTABLE SET
How to make it. See RADIO WORLD, dated May 16, 15c. per copy, or start your subscription with that number. RADIO WORLD, 1493 Broadway, New York City.

A POWERFUL 3-TUBE REFLEX, by H. E. Wright. Send 15c for May 23 issue, RADIO WORLD.

in steps of 500 watts will be required. This announcement, just made by the Department of Commerce, is expected to make clear reception possible during the warm period, in spite of the increase of static.

"In taking this action," says Solicitor Davis, of the Department of Commerce, "we are endeavoring to satisfy the demand of broadcast listeners that the use of increased power be permitted, in order to overcome static conditions which are making reception difficult."

Data Hard to Get

Since the Third National Radio Conference authorized Class B stations to increase their power comparatively little reliable data have been collected regarding the effects. A number of stations are now using 1,500 and 2,000 watts. Beyond the fact that the service range of the station is increased, little else is known.

In some instances it has been found that stations located inside cities could not use more than 1,500 watts power because of occasioning interference. In almost all cases, stations located outside of cities have not caused serious interference by increasing their power.

So far it is known that two stations—WLW and WSAI, both located outside of Cincinnati—will take advantage of the Commerce ruling and increase their power to 5,000 watts. Wherever possible, other stations are expected to take similar action.

Effects Being Studied

The Bureau of Standards has been measuring the strength of signals from the higher power and studying the effects of the increase in power. When the next radio conference meets in Washington, considerable data probably will be available which may decide whether in the future fans may depend upon small power local stations or high power distant ones for their reception.

Since small local stations cannot expect to compete with those located in New York, Boston, Philadelphia, Chicago and other large cities in quality of programs, there is little doubt that if superpower is authorized, smaller ones will be put out of business.

Dr. George K. Burgess, Director of the Bureau of Standards, believes that the

question of best service to the fans will probably be the deciding factor.

"We face on the one hand," says Dr. (Concluded on next page)

Obsolete

The HEART of the Circuit is AMPERITE
The "Self-Adjusting" Rheostat

As the heart controls the flow of blood through the body, so AMPERITE, the self-adjusting rheostat, controls the flow of current through the tubes—automatically—never allowing too much to injure the tubes, and always permitting true tone qualities with proper volume. No hand rheostats. No guessing. Simplifies wiring. Improves operation. Used in over 50 leading sets and circuits. \$1.10 everywhere.

RADIALL COMPANY
Dept R W -8, 50 Franklin Street, New York City

Write for **FREE** Hook-ups

AMPERITE
REG. U.S. PAT. OFF.
"means right amperes"

RADIO MAILING LISTS

15870 Radio Dealers	Per M \$7.50
970 Radio Dealers in Mexico	Per List 10.00
1808 Radio Mfrs.	Per List 18.00
2324 Radio Jobbers	Per List 20.00
1123 Radio Jobbers, rated \$5,000 and up	Per List 18.00
714 Radio Jobbers, rated \$50,000 and up	Per List 16.00
597 Radio Mfrs. making complete sets	5.00
126 Radio Battery Mfrs.	2.50
123 Radio Cabinet Mfrs.	2.50
60 Crystal mounters for Wireless apparatus	2.50
25000 Radio Amateurs	Per M 7.50
625 Phonograph and Music Radio Dealers	5.00
7400 Radio owners	Per M 7.50

Guaranteed 98% correct. Ask for Price List and all other lists.

A. F. Williams, Mgr., List Dept.
Established 1880
166 W. Adams St. Chicago, Ill.

Two-For-Price-of-One Subscription Blank For NEW RADIO WORLD Subscribers Ordering NOW

Radio World has made arrangements

This is the way to get two publications

- To offer a year's subscription for any one of the following publications
- with one year's subscription for RADIO WORLD
- RADIO NEWS or
- POPULAR RADIO or
- RADIO BROADCAST or
- WIRELESS AGE or
- RADIO DEALER or
- RADIO JOURNAL or
- RADIO (San Francisco) or
- BOYS' LIFE

- for the price of one:
- Send \$6.00 today for RADIO WORLD
- for one year (regular price)
- for 52 numbers)
- and select any one of the other
- eight publications for twelve months.
- Add \$1.00 a year extra for
- Canadian or Foreign postage.
- Present RADIO WORLD subscribers
- can take advantage of this offer by
- extending subscriptions one year
- if they send renewals NOW.

RADIO WORLD'S SPECIAL TWO-FOR-PRICE-OF-ONE SUBSCRIPTION BLANK

RADIO WORLD, 1493 Broadway, New York City.
Enclosed find \$6.00, for which send me RADIO WORLD for twelve months (52 numbers), beginning.....
and also without additional cost, Radio News, or Popular Radio, or Radio Broadcast, or Wireless Age, or Radio Dealer, or Radio Journal, or \$10.00 for two yearly subscriptions.

Indicate if renewal. Offer Good Until June 10, 1925

Name

Street Address

City and State

Dry Battery Transmission from Plane Is Success

A MESSAGE was flashed from apparatus on a navy airplane to Professor C. M. Jansky in the department of

electrical engineering at the University of Minnesota, who replied to it.

Officers in charge of the experiments said its success marked a new radio triumph, in that it is the first time such a message has been sent on a machine which works without a generator and simply on dry batteries.

They pointed out that this is extremely important to the army and navy, since with the old form of machine messages might be sent only while the plane was in the air and while its propeller furnished the power

for a generator, while now an operator may send messages when the plane is on the ground.

Immediately after the test Lieut. Commander E. F. McDonald Jr., who had a hand in perfecting and building the new instrument, announced that he will take such a outfit with him when he goes in June on the polar expedition into the Arctic regions with Donald MacMillan.

Thrill of Getting DX Discussed by Expert

(Concluded from preceding page)

Burgess, "the fact that the nearby local stations are the most satisfactory from the standpoint of technical quality of reception and low cost of receiving apparatus, and on the other hand the fact that the higher the power used at a station the greater is the territory that can be served by a single station and the more economically practicable it becomes to interconnect stations for the simultaneous broadcasting of nationally important material.

"A number of considerations should guide thought upon the problem thus presented. Since the most satisfactory quality of reception is obtained when the incoming signal is relatively strong, the person interested primarily in radio broadcasting as an actual service, the delivery to him of agreeable entertainment and important news and instructions is served best at the present time by the local stations.

DX Hounds Still Busy

"There is on the other hand a vast proportion of the people who derive their chief satisfaction from radio through the thrill of listening to broadcasting from great distances. The satisfying of this interest must and will continue, through the operation of many stations of about the power and location of present stations.

"It must be recognized, however, that all long distance radio reception is now more of a pastime than a service, since long distance reception is necessarily subject to the interruptions and disturbances from atmospheric discharges and electrical interference.

"There is always a certain amount of random electrical disturbance in the atmosphere, and to insure radio reception of high quality not vitiated in part by these disturbances it is necessary that the received signal have a signal intensity above a certain minimum value. It is, therefore, not the power of the transmitting station nor the sensitivity of the receiving set which gives the real limit to the distance of reception, but rather the general level of intensity of atmospheric disturbances. All the vast engineering and amateur effort to make more sensitive sets can henceforth be considered as being spent for the benefit of radio listeners who desire to hear distant stations rather than for the listener who desires to secure reception of high quality."

(Copyright 1925 by Stevenson Radio Syndicate)

Radio Tubes Exchanged



Send us your old tube—any make—any condition—and we will send you a Brand New Guaranteed Tube, of whatever type you require (except WD11), for \$1.75. All shipments by insured Parcel Post C. O. D. Send no money—order today.

\$1.75 C.O.D.

D-R-C RADIO CO.

331 S. LaSalle St. Chicago, Ill.

Superheterodyne Manual—Just Out!

The book you have been waiting for

ONLY \$1.00

Regular Price, \$2.50

The big feature of the book is the manner in which the diagrams and illustrations are reproduced. Forced perspective drawings show you the exact location for placing of the parts and the correct manner in which to wire the set. Many months of laboratory work were required to gather the material for this book.

Remember—the regular price of this book is \$2.50. The special introductory price is only \$1.00—good only for a very limited time. Act Now.

Nothing just like it on the market. It fills a long felt want among those who are in need of accurate constructional details for building the 45,000 cycle receiver. We will cheerfully refund your money if you are not entirely satisfied with your purchase of this book.

CONTENTS

Tells you how to build the famous 45,000 cycle BEST superheterodyne with all of its latest improvements. Tells you how to build superheterodynes operating with either dry cells or storage batteries. Tells you how to design various types of supers—including one for portable use. Gives you the complete list of parts needed.

Baseboard layouts and photographic diagrams are a special feature of the book.

ONLY \$1.00

Regular Price, \$2.50

You can actually start building a superheterodyne by following the very simple instructions contained in the Superheterodyne Manual. No experience necessary. The many perspective drawings, photographs and illustrations show you how to build the set—step by step.

Order your copy now and save \$1.50. A limited number of copies only will be sold at the low price of \$1.00. Get your copy right now. Don't delay.

Mail orders will be given prompt attention. Send a one dollar bill, check or money order today and get your copy. The book will be sent to you postpaid. One dollar covers the entire charge. There are no further payments of any kind to be made. This introductory offer good only for 30 days.

We guarantee delivery of this book within eight hours after your order reaches us.

Mail This Coupon Now And Save \$1.50

"RADIO," Pacific Building, San Francisco, Cal.

Here is \$1.00. Send me at once a copy of the \$2.50 Superheterodyne Manual, in accordance with your special introductory offer.

NameCity

AddressState

FILL OUT AND MAIL NOW

SUBSCRIPTION BLANK

RADIO WORLD

RADIO WORLD

Please send me RADIO WORLD for months, for which please find enclosed \$.....

1493 Broadway, New York City

SUBSCRIPTION RATES:

- Single Copy\$.15
- Three Months 1.50
- Six Months 3.00
- One Year, 52 Issues..... 6.00
- Add \$1.00 a Year for Foreign Postage; 50c for Canadian Postage.

EVEREADY Radio Batteries —they last longer

THE BABY PORTABLE, by Herbert E. Hayden. A 1-tube DX set on a 7 1/2 x 5 1/2" panel. Send 30c for May 16 and 23 issues to RADIO WORLD, 1493 Broadway, New York City.

GETTING BETTER QUALITY FROM AUDIO, by Brewster Lee. Last AF stage connected to two tubes in parallel. Send 15c for May 16 issue to RADIO WORLD, 1493 Broadway, New York City.

STATION SLOGANS

- KDKA—Pittsburgh, Pa.—“The World’s Pioneer Broadcaster.”
- KFAF—Denver, Colo.—“The Voice from the Rockies.”
- KFKX—Hastings, Nebr.—“The Empress of the Air.”
- KGW—Portland, Oreg.—“The Lumber Capital of America and the Gateway to Mount Tacoma.”
- KLX—Oakland, Calif.—“Where Rail and Water Meet.”
- KNX—Hollywood, Calif.—“The Voice of Hollywood.”
- KOA—Denver, Colo.—“The Rocky Mountain Broadcasting Station.”
- KYW—Chicago, Ill.—“The Twenty-four-hour Station.”
- WBBR—Rossville, N. Y.—“The Watchtower Station.”
- WBT—Charlotte, N. C.—“Queen City of the South.”
- WCAD—Canton, N. Y.—“The Voice of the North Country.”
- WCBD—Zion, Ill.—“Where God Rules, Man Prospers.”
- WCBZ—Chicago Heights, Ill.—“Where the Lincoln and Dixie Highways Meet.”
- WDBH—Worcester, Mass.—“The Voice from the Heart of the Commonwealth.”
- WEAF—New York, N. Y.—“The Voice to the Millions.”
- WEAR—Cleveland, Ohio.—“The Wave from Lake Erie.”
- WEBH—Chicago, Ill.—“The Voice of the Great Lakes.”

Atwater Kent in Debut Radios from Plane as Wife Listens

A RADIO man, A. Atwater Kent, manufacturer, never talked into a microphone until he made his debut aboard the navy dirigible Los Angeles flying over three States with thirty civilian passengers.

Mr. Kent, before going to Lakehurst, had installed a radio set and loud speaker in his automobile. His wife sat in the car near the hangar and listened to the broadcasting.

RADIO TUBES DIRECT NO DEALER PROFIT

Postage Prepaid—Satisfaction Guaranteed
 ONE—“Goode” Two-o-one A Tube.....\$1.89
 THREE—“Goode” Two-o-one A Tubes..... 5.00
 The above is a five volt, quarter-ampere tube for use on storage batteries and can be used either as a Detector or an Amplifier.

THE GOODE TUBE CORP., Inc.
 OWENSBORO (Dept. B), KENTUCKY

RADIO CATALOG AND HOOK-UPS FREE

Our great new catalog, fresh from the press, contains the very newest in complete sets, parts and accessories—hundreds of amazing bargains. 250,000 customers testify to our wonderful values and reliability. Complete instructions with diagrams for making most practical popular sets FREE. SEND QUICK for your copy. (Please include name of friend who is interested in Radio.)

THE BARAWIK CO.
 Dept. 121 32-48 So. Clinton Street Chicago

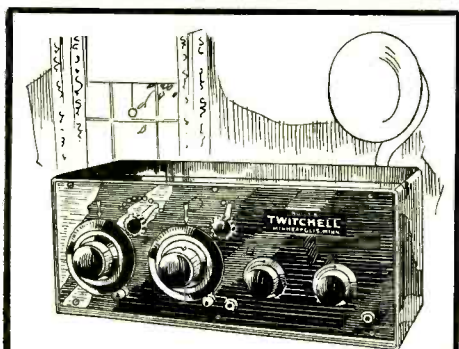

ONLY THREE TUBES

and it is the equal of any five-tube set ever built. It has selectivity and volume equal to any Super-heterodyne or Neutrodyne.

It has brought in Honolulu, Paris, London and other foreign stations on a loud speaker.

It gets distant stations while a 500-watt station only three blocks away is broadcasting.

Any novice can build one successfully from our diagrams with complete instructions and special coil.

PRICES

Diagram instructions and coil..... \$5.00

Three-tube instrument ready to use..... 50.00

Build or buy one of these wonderfully sensitive instruments and you will want no other. All goods shipped prepaid.

S. A. TWITCHELL CO.

1930 WESTERN AVE. MINNEAPOLIS, MINN.

OLD MAN STATIC “KILLED” AT LAST

Statchoke Has Startled the Radio World—Insures Clear, Long Distance, Summer Reception

Kansas City, Mo., (Special)—The long promised invention which insures clear, long distance, “summer radio” without the agony of static, has just been announced here. Radio experts and fans who have tested this new imported invention, pronounce it marvelous. Awarded Certificate of Merit by Radio News of Canada.

In addition to reducing static to a minimum, the Statchoke increases the volume as well as clarity of distant reception, sharpens the selectivity of tuning in, eliminates that harshness of the tubes so noticeable on local loud speaker reception and acts as a safety lighting arrester.

The Statchoke somewhat resembles a small transformer, and by a system of coils it allows only the correct current value to enter the set, choking out other high current variation from the aerial, which is passed off through a secondary ground connection.

So confident are the American distributors that Statchoke will give you clear long distance summer reception that they have set aside 25,000 units for initial distribution direct to the radio fans, at a special price of only \$2.50 each.

If interested write today to Radio Dept., Imperial Laboratories, 9525 Coca Cola Bldg., Kansas City, Mo., and the Statchoke will be sent you by insured mail. Write today as this is a special offer and may not appear again.

Used in 80% of all receiving sets in Great Britain. Eliminates tube noises. Pulls in inaudible stations.

The “BRETWOOD”

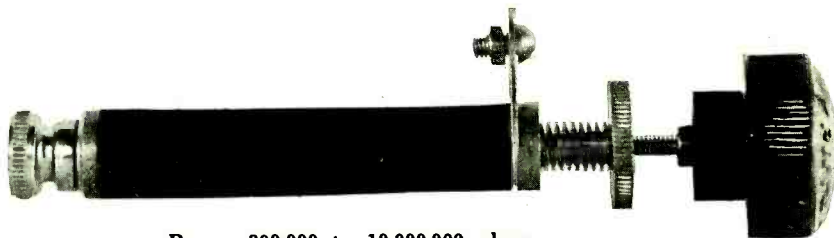

Range 300,000 to 10,000,000 ohms

Variable Grid Leak

Bretwood, Ltd., London, Eng., Sole Patentees and Owners

The Bretwood Variable Grid Leak used in a detector tube circuit, strengthens weak signals, makes DX easier, eliminates tube noises and internal howling, due to incorrect leakage from the grid of the tube.

By simply turning the knob the carrier wave may be tuned from the silent point to maximum audibility. The Bretwood is absolutely noiseless in operation and will hold any given setting indefinitely. It is a single-hole panel mount leak.

The Bretwood Variable Grid Leak, tested in the National Physical Laboratory (the official laboratory of Great Britain) and by RADIO WORLD’S Laboratory, proved to be a scientifically accurate instrument. The total range, 9,700,000 ohms, produced by 25 turns of the knob, make a minute adjustment very simple.

The Bretwood Variable Grid Leak is constructed on a different principle and produces better results than any other grid leak. In its specially-constructed barrel is a patented plastic, non-drying resistance material, in which there is a small movable plunger which again moves freely in an absorbent cartridge which gives the setting of the instrument great stability, making it far superior to the graphite, carbon or fibre, compressed or decompressed, resistance elements. It can be used in the most critical circuits with the greatest success.

The North American Bretwood Company

Sole Distributors for United States and Canada

1505 BROADWAY

NEW YORK CITY

Sent You on a Money Back Absolute Satisfaction Guarantee

NOTE TO RADIO MANUFACTURERS

Upon request, we will send any known radio manufacturer a sample of the Bretwood Variable Grid Leak, which will often double the DX value of a receiver and lessen by half a manufacturer’s complaints.

A set with a FIXED Grid Leak may work perfectly where tested, while it needs a VARIABLE Grid Leak so that set may be adjusted to the locality where used.

The Bretwood Variable Grid Leak will often bring in distant stations on a loud speaker that can only be heard faintly with a phone.

The North American Bretwood Co.,
 1505 Broadway, New York City,
 Room 326

Gentlemen:

Enclosed find \$1.50 for which you will please send me one Bretwood Variable Grid Leak prepaid. Satisfaction guaranteed or my money back after trial within ten days of receipt by me.

NAME

STREET

CITYSTATE

4-Tube Set Neatly Made

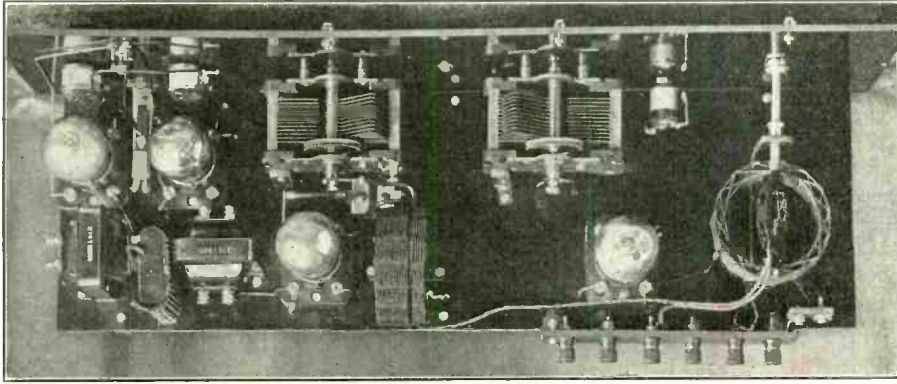

A NEAT PIECE OF WORK indeed is this 4-tube DX receiver, built by E. L. Gross, of 1148 Robeson Street, Reading, Pa., from constructional data by J. E. Anderson. Slightly improved, this circuit was published in the January 21 issue. Mr. Gross says this is his favorite receiver.

The LARGEST RADIO STORES in AMERICA

Hook-ups!
All the latest and best Kits in our new
RADIO CATALOG

FREE

NO other Radio Catalog includes such a complete assortment of the best and latest Knock-Down Kits, Parts and Accessories. You need this book—Write for your FREE copy today!

We Save You Money!
Our business is to buy up manufacturers' and government surplus stocks, jobber and dealer bankrupt stocks—but only brand-new, fully guaranteed, nationally advertised apparatus. Our catalogue crammed with bargains.



509 So. State St., CHICAGO, ILL., Dept. R.W.3

A SET FOR REDUCING STATIC

with diagrams; in RADIO WORLD, dated May 9, 15c. per copy, or start your subscription with that number. RADIO WORLD, 1493 Broadway, New York City.

A POWERFUL 3-TUBE REFLEX, by H. E. Wright. Send 15c for May 23 issue, RADIO WORLD.

The Weekly Rebus

WHAT does this Rebus represent?
Send answer to Rebus Editor,
RADIO WORLD, 1493 Broadway, New York



City. The names of those sending the solution will be published.

- S. Maddy, 3050 W. 56th St., Cleveland, O.
- George Cobas, 1020 Jackson St., San Francisco, Cal.
- Adolph Escalante, 1100 Jackson Ave., San Francisco, Cal.
- James Gaylard, 2600 4th St., N. St. Petersburg, Fla.
- H. Roy Scott, 1750 Mahan Ave., Bronx, N. Y. C.
- E. W. Simmons, 141 Central Ave., San Francisco, Cal.
- Isidore Weiss, 608 East 9th St., N. Y. C.
- Leonard Browe, R. R. No. 2, Box 4, Menomonie, Wis.
- W. B. Hermann, 1818 Avenue L, Brooklyn, N. Y.
- L. E. Rowle, 3011 Columbia St., Vancouver, Wash.
- Otho Riffle, 1402 Park Ave., Indianapolis, Ind.

A 3-TUBE REFLEXED NEUTRODYNE, by Percy Warren. Send 15c for May 16 issue, RADIO WORLD.



For Battery, Antenna and Ground Leads—

Jones MULTI-PLUG

THE STANDARD SET CONNECTOR

HOWARD B. JONES

618 S. CANAL STREET CHICAGO

BUY THE FILE-KO LIGHTNING ARRESTER
SCIENTIFICALLY CORRECT
with the \$100.00 Guarantee

Warranted to protect your radio from lightning, with a guarantee to pay you \$100 or to repair you set, should it be damaged by lightning through any fault of the arrester.

Listed as STANDARD under the re-examination service of the National Board of Fire Underwriters. If your dealer has none, send his name with remittance direct to Dept. RW 530.

DX INSTRUMENT CO.
Harrisburg, Pa.

\$1.50
\$2.50 IN CANADA

OPERATONE RADIO TUBES

Guaranteed the Best

Type 201A
Type 200
Type 199 \$1
199 with Standard Base EACH
Type WD12, \$1.25

Mail Orders Filled. Dealers, Jobbers, Write for Discounts.

OPERATONE TUBE CO.
Room 411
324 West 42nd Street, New York City

RADIO WORLD'S QUICK-ACTION CLASSIFIED ADS.

10 CENTS A WORD. 10 WORDS MINIMUM

PATENTS—Write for free Guide Books and "Record of Invention Blank" before disclosing inventions. Send model or sketch of your invention for our Inspection and Instructions Free. Terms reasonable. Radio, Chemical, Mechanical, Electrical and Trademark experts. Victor J. Evans & Co., 924 Ninth, Washington, D. C.

2650 MILES DISTANCE with one tube. We send complete understandable instructions with panel layout, picture diagrams, etc., for 25c. Or **BIG BOOKLET FREE**. VESCO RADIO CO., Box 117-RW Oakland, California.

A PUSH-PULL AF AMPLIFIER with diagrams, in RADIO WORLD dated May 9. 15c per copy, or start your subscription with that number. RADIO WORLD, 1493 Broadway, N. Y. C.

GETTING BETTER QUALITY FROM AUDIO, by Brewster Lee. Last AF stage connected to two tubes in parallel. Send 15c for May 16 issue to RADIO WORLD, 1493 Broadway, New York City.

RECENT BACK NUMBERS

of RADIO WORLD, 15 cent each, or any seven for \$1. Address Circulation Manager. RADIO WORLD, 1493 Broadway, New York City.

WANT TO MAKE MONEY? Of course, you do! Fast selling new invention; write quick for territory. Have own business. Konkle, 192 Market St., Newark, N. J.

RADIO HOSPITAL Specialists in Neutrodyne and Superheterodynes. Radio Central, Abilene, Kansas.

SONG POEM WRITERS—Have proposition. Ray Hibbeler, D83, 4040 Dickens Ave., Chicago, Ill.

RADIOLA SUPER-HETERODYNE (new)—\$169.00 prepaid. G. Simms, Lake, New York.

THE SHORT-WAVE RECEIVER REINARTZ WILL USE IN ARCTIC. Full wiring directions. Send 15c for May 16 issue, RADIO WORLD, 1493 Broadway, New York City.

THE BLUEBIRD REFLEX 2-tube earphone marvel by Capt. Peter V. O'Rourke. Send 15c for February 7 issue. RADIO WORLD, 1493 Broadway, New York City.

A \$5 HOME-MADE LOUDSPEAKER, by Herbert E. Hayden, in Feb. 7 and March 4 issues. Send 30c for both copies. RADIO WORLD, 1493 Broadway.

EARN \$5-\$10 WEEKLY, addressing, mailing circulars. Send stamped envelope for particulars. Palace Mail Co., Toledo, Ohio.

DINING AND SLEEPING CAR CONDUCTORS (White) Exp. unnecessary. We train you. Send for book of Rules and application. Supt. Railway Exchange, Sta. C, Los Angeles.

AGENTS—WRITE FOR FREE SAMPLES. Sell Madison "Better-Made" Shirts for large Manufacturer direct to wearer. No capital or experience required. Many earn \$100 weekly and bonus. Madison Mfrs., 501 Broadway, New York.

HOW TO MAKE IDEAL COILS, for tuning with .0005 and .001 mfd. condensers. Described by J. E. Anderson in March 7 and 14 and April 11 issues. Send 45c for all three. RADIO WORLD, 1493 Broadway, New York City.

A DX TRANSMITTER, by C. H. West, May 23 issue, RADIO WORLD, 15c.

A SIMPLE 1-TUBE DX SET FOR THE NOVICE, by Percy Warren. Send 15c for May 23 issue, RADIO WORLD.

EASILY-MADE CRYSTAL SETS. Send 15c for May 16 issue, RADIO WORLD.

Builders Rave Over Diamond

(Concluded from page 9)

up with the developments as you publish them.

I have had a lot of fun and learned a lot.

R. F. GALLOWAY,
Pastor, Community Church,
Postville, Ia.

* * *

Actor Prefers Diamond to Super-Heterodyne

RESULTS EDITOR:

MANY thanks for publishing my humble praise of Herman Bernard's Diamond of the Air. Here is a list of travel that my wife and I took last night and this morning:

We came home to our hotel here in Detroit (where we are now playing) at 10:20 p. m., and until 1 a. m. tuned in the following on the loudspeaker: WOC, Davenport, Iowa; WOR, Newark, N. J.; WBAP, Fort Worth, Texas; KFI, Los Angeles, Cal.; KGW, Portland, Ore.; KPO, Oakland, Cal.; WCCO, Minneapolis and St. Paul; KOA, Denver, Colo.; KJR, Seattle, Wash.; KHJ, Los Angeles, Cal.

These are only the distant points. Cincinnati, Cleveland, Chicago, Kansas City, etc., are almost local stations from here with this set. In fact, anything within 600 miles is mine when I want it. A Super-Heterodyne may be the Rolls-Royce of radio, but when I see one that is as consistent as this 4-tuber, I'll change. So

far I haven't seen one that good. The proof of the pudding is the eating of it, and the proof of a radio set is trying it. I've tried both and the Diamond of the Air is "IT."

I am sailing for Australia in October and the Diamond goes along. I will be glad to let you know how she performs over there.

HARRY ROSS,
(Keating & Ross),
307 Woods Theatre Bldg.,
Chicago, Ill.

* * *

Only Set That Tunes Out Station Right Nearby

RESULTS EDITOR:

PLEASE send me a nameplate for The Diamond of the Air. I am very proud of this set. It is deserving of a name. I am using four 301A tubes, as I had them on hand, also No-Loss condensers; coils, Fisher 45-degree for detector, with home-made RFT on 4" diameter bakelite tubing. The loop also is home-made, wound on bare wooden sticks.

On a 100-foot aerial I have brought in the following on the speaker: KFKX, Hastings, Neb.; WDAF, Kansas City, Mo.; WOAW, Omaha, Neb.; WBBM, Chicago, (also on the loop); WCBZ, Zion, Ill., (also on the loop); WOC, Davenport, Ia., (also on the loop); KOA, Denver, Col., and all the stations this side of Denver of any power. It is the only set I have built that tunes out WAHG, as I live only ten blocks (less than 1/2 mile) from this powerful station. I always watch RADIO WORLD for Herman Bernard's articles. He de-

serves great praise for designing and lucidly describing The Diamond of the Air (issues of April 4, 11 and 18, with trouble-shooting April 25).

MAURICE C. EDDY,
10,111 124th St.,
Richmond Hill, N. Y.



Static

"HOW TO KEEP STATIC OUT OF YOUR RADIO"

NEW COPYRIGHTED PLANS. \$1.00

LEON LAMBERT
WICHITA, KANSAS

EVERY SET BUILDER NEEDS THIS "Morsing Bus-Bar Union"

Makes for quick assembling. Repairs can be made by using Morsing Bus-Bar Union without taking set apart.

Assemble round or square Bus-Bar and solder three wires at a time. Order No. 1 for No. 14, No. 2 for 12 wire. Send 25 cents for enough for building one set, or ten dozen for \$1.00.

Newark Watch Case Material Co.
15 Ward Street Newark, N. J.
DISTRIBUTORS WANTED

DX, VOLUME, SELECTIVITY

All Three Marvelously Combined in



"A Gem, a Jewel and a Joy"

Described by Herman Bernard in the April 4, 11 and 18 issues, with trouble-shooting in the April 25 issue. That is the 3-control set.

The Diamond as a 2-control set, using a double-condenser, was described in the May 23 and 30 issues. If you are going to build the 2-control set, be sure to get the four other numbers also, for full information.

Either set works fine on loop or outdoor aerial.

Get your full measure of enjoyment from radio reception by building this set. Just the thing for fine summer reception.

Send 60c for the April 4, 11, 18 and 25 issues, or 90c for those and the May 23 and 30 issues, or start your subscription with the earliest dated number. Send \$6.00 for yearly subscription and these six numbers will be sent free. Address Circulation Manager, RADIO WORLD, 1493 Broadway, New York City.

NEUTRODYNE KIT \$19.75

Complete kit of licensed Neutrodyne parts including panel, tube sockets, rheostats, jack, fixed condensers and grid leak. Neutroformers complete with variable condensers and neutrodons. Every part included, even to screws and wire. Easy read plans.

Send No Money Order by Postcard
Pay the Postman
HELENA MONTANA RADIO SURPLUS STORES

WANTED IN EVERY LOCALITY

An agent to sell Biltmore Master Reflex Receivers to dealers, on our plan which allows the dealer to make summer profits equal winter profits.
The receiver with the "Guaranteed Best Tone"
BILTMORE RADIO COMPANY
Boston 30, Mass. Dept. R.W. 94 Green St.

SAVE \$1.50 ON COST OF NEW TUBES BY HAVING YOUR OLD TUBES REBUILT

AT \$1.50 EACH

Guaranteed equal to new. Send us your tubes by parcel post. We return them parcel post, C.O.D., and try to maintain 24-hour service.

400 Old Colony Ave. Boston, Mass.

HARVARD RADIO LABORATORIES

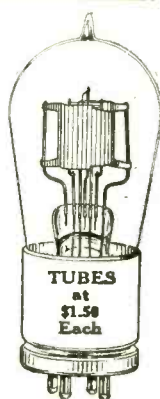

Free Mailing Lists

Will help you increase sales. Send for FREE catalog giving counts and prices on classified names of your best prospective customers—National, State, Local—Individuals, Professions, Business Firms.

99% Guaranteed by refund of 5¢ each

ROSS-GOULD CO. 313 N. 10th St. St. Louis

Coming Events

[Readers are requested to send in dates and places of future events not scheduled in this department.]

JUNE 8 to 11—Annual meeting of Associated Manufacturers of Electrical Supplies; also conference of Electrical Jobbers' Assn., Hot Springs, Ark.

JUNE 15 to 18—Radio Display Show, Hotel Chase, St. Louis, Mo.

AUG. 22 to 28—3d Annual Pacific Radio Exposition, Civic Auditorium, San Francisco. Write P. R. E., 905 Mission St., San Francisco.

SEPT. 5 to 12—Third Annual National Radio Exposition, Ambassador Auditorium, Los Angeles, Cal. Address Waldo K. Tupper.

SEPT. 6 to 12—National Radio Exposition, Grand Central Palace, N. Y. C. Write American Radio Exp. Co., 522 Fifth Ave., N. Y. C.

SEPT. 14 to 19—Second Radio World's Fair, 258th Field Artillery Armory, Kingsbridge Road and Jerome Ave., N. Y. C. Write Radio World's Fair, Times Bldg., N. Y. C.

SEPT. 14 to 19—Pittsburgh Radio Show, Motor Square Garden. Write J. A. Simpson, 420 Bessemer Bldg., Pittsburgh, Pa.

SEPT. 23 to 21—International Radio Exposition, Steel Pier, Atlantic City, N. J.

SEPT. 23 to OCT. 4—International Wireless Exp., Geneva, Switzerland.

SEPT. 28 to OCT. 3—National Radio Exposition, American Exp. Palace, Chicago. Write N. R. E., 440 S. Dearborn St., Chicago, Ill.

OCT. 5 to 10—Second Annual Northwest Radio Exposition, Auditorium, St. Paul, Minn.

OCT. 5 to 11—Second Annual Radio Show, Convention Hall, Washington, D. C. Write Radio Merchants Association, 233 Woodward Bldg.

OCT. 17 to 24—Brooklyn Radio Show, 23d Regt. Armory. Write Jos. O'Malley, 1157 Atlantic Ave., Brooklyn, N. Y.

OCT. 12 to 17—St. Louis Radio Show, Coliseum. Write Thos. P. Convey, manager, 737 Friaco Bldg., St. Louis, Mo.

OCT. 19 to 25—Second Annual Cincinnati Radio Exp., Music Hall. Write G. B. Bodenhoff, care Cincinnati Enquirer.

NOV. 19 to 25—Milwaukee Radio Exp., Civic Auditorium. Write Sidney Neu, of J. Andrae & Sons, Milwaukee, Wis.

NOV. 17 to 22—4th Annual Chicago Radio Exp., Coliseum. Write Herrmann & Kerr, Cort Theatre Bldg., Chicago, Ill.

DEC. 1 to 6—Boston Radio Show, Mechanics' Hall. Write to B. R. S., 209 Massachusetts Ave., Boston, Mass.

HIGH QUALITY—LOW PRICE

Masterton

REG. U.S. PAT. OFF.

Type M 199A. Standard Base.
3-4 Volts .06 Amp. Detector and Amplifier. To be used with dry cells in place of 201A Tubes.

Type M 199. 3-4 Volts .06 Amp. Amplifier and Detector. The Ideal Tube for the call of the open.

Type M 12. 1½ Volts .25 Amp. Platinum Filament Amplifier and Detector. The economical dry cell tube.

All Types
Actual Sizes

All types of
Mastertone
Tubes

\$ **2.00**



Type M 12



Type M 199



Type M 199A



Type 201A.

A powerful amplifier with remarkable quality.

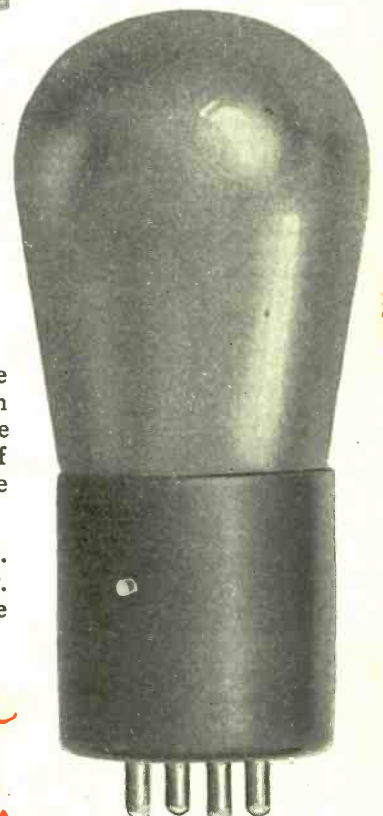

Type 201A

A double action tube. It amplifies as it detects.

MASTERTONE RADIO TUBES

are the ultimate achievement in Tube construction. Are rigidly tested before leaving the factory. Carry with them an ABSOLUTE "NO-RED-TAPE" GUARANTEE. Are backed by a most liberal and co-operative sales policy. If your dealer is unable to supply you please send us his name and order direct. Always mention type when ordering.

We invite all radio dealers to write for our proposition. Dealers and distributors required in all parts of the country. Here is an opportunity for an exclusive agency that will be of value not only for profit but also for prestige.

MASTERTONE RADIO CO.

903 BROAD STREET

NEWARK, N. J.

Telephone Mitchell 0966